

Product Guide 2026



NATURAL COMFORT

Over 35 years of expertise in heat pumps.

Clivet has been leading the way in heat pump innovation since 1989. We were among the first to recognize the technology's potential for efficient and sustainable comfort – and our dedication to innovation hasn't wavered since.

Purpose-built solutions.

Clivet engineers its solutions from the ground up to offer specialized systems designed for a diverse range of applications and environments. Boasting the widest range of heat-pump solutions, our flexible, adaptable approach ensures a perfect fit for your specific requirements.

Crafted in Europe, made for North America.

As a pioneer in heat pump technology in Europe, Clivet delivers innovative solutions tailored to diverse market needs worldwide. Our products are specifically designed to meet the comfort demands of the North American market, built on four key pillars: dedicated product development, industry-leading manufacturing and quality excellence, and the strength of our partners' premium pre and post-sales service network.

A simplified product experience.

Clivet systems streamline every step, from simplified design and installation to effortless operation and control. Engineered for efficiency from the ground up, Clivet delivers unparalleled ease of use, lower operating costs, and a lasting commitment to sustainability.



COMFORT FOR THE
PLANET & PEOPLE

OUR NUMBERS

53.500 m²
OF PLANTS IN FELTRE
(BELLUNO) AND VERONA
(UTA PRODUCTION)

1000+
EMPLOYEES IN ITALY
AND ABROAD

8 BRANCHES:
GREAT BRITAIN,
GERMANY, INDIA,
RUSSIA, UAE, CHINA,
BALKANS AND FRANCE

2016
STRATEGIC ALLIANCE
WITH MIDEA GROUP

2024
MIDEA GROUP
277 FORTUNE
GLOBAL
500

100+
COUNTRIES
WE EXPORT TO

700+
PROFESSIONALS
WORLDWIDE
• SALES NETWORK
• DISTRIBUTORS
AND WHOLESALERS
• INSTALLERS
• SERVICE CENTRES

2023
FIRST
SUSTAINABILITY
REPORT

2025
MBT CLIMATE,
THE EUROPEAN UMBRELLA
ORGANISATION
OF MIDEA BUILDING
TECHNOLOGIES (MBT),
IS BORN

Clivet Principles

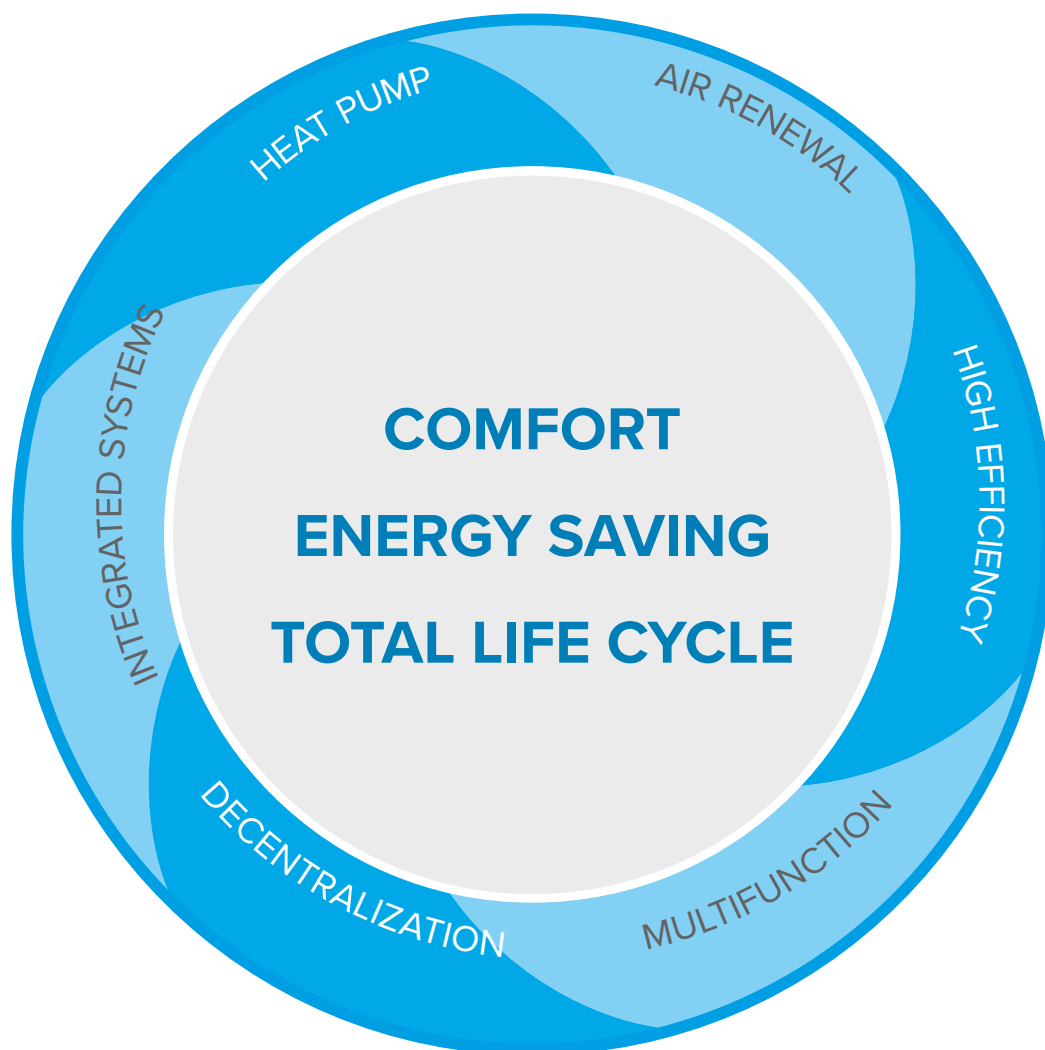

CLIVET PRINCIPLES

All Clivet systems are based on six key principles that make Clivet's products and systems unique.

These principles are the basis for making application-specific systems, which have always been part of Clivet's DNA.

The six key principles are the foundation of Clivet's entire outlook, and they are the driving force behind Clivet's development of sustainable systems of the future.

Heat Pump Technology

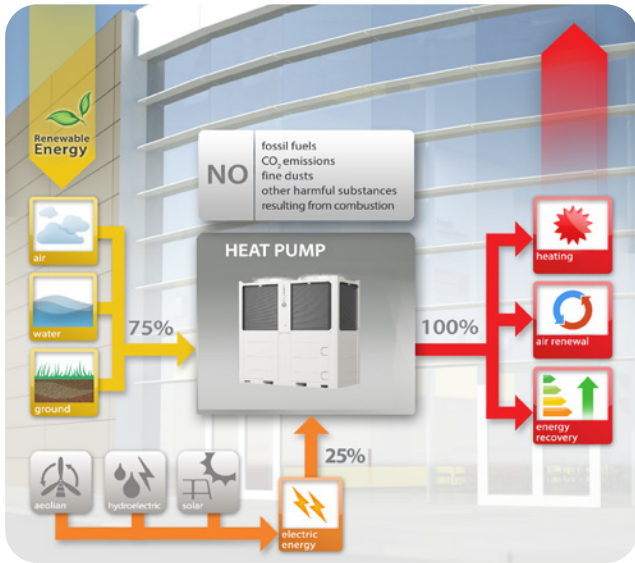

Heat pumps are the technology of the future because they are significantly more efficient than traditional combustion systems:

- ✓ Reductions of 50% in Primary Energy, CO₂ and Running Costs
- ✓ Extensive use of Renewable Energy

Due to Clivet's heat pump technology, Clivet's systems guarantee:

- ✓ A single system for both heating and cooling
- ✓ Controlled mechanical ventilation with innovative thermodynamic recovery
- ✓ Free production of domestic hot water in summer
- ✓ Simultaneous heating and cooling to fulfill simultaneous loads

High Seasonal Efficiency

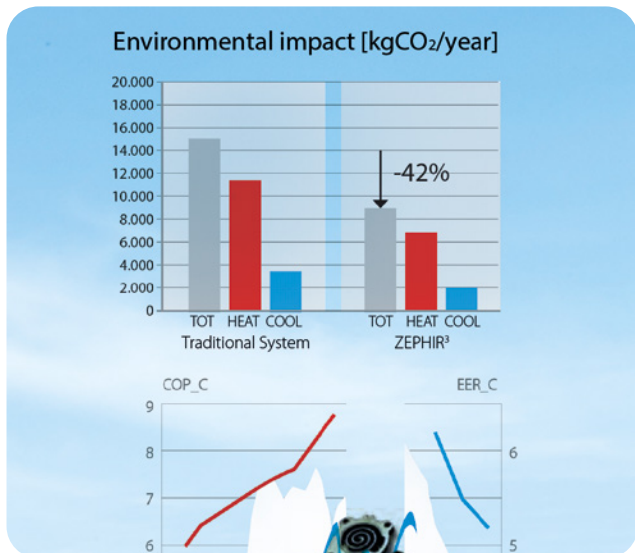

ZEPHIR³, Office Building in London, case study

Every application has different needs which vary depending on multiple factors, including different indoor and outdoor climatic conditions, crowding and thermal loads.

Clivet systems are designed to meet the specific needs of every application, thereby optimizing the use of the system's resources to reach top seasonal efficiency levels thanks to:

- ✓ One systemic solution
- ✓ Use of the most favourable resources
- ✓ Full control over the system
- ✓ Continuous capacity modulation

Polyvalent



Clivet's multifunction systems include all the elements to ensure year-round comfort. Clivet has developed complete dedicated systems that use the following functions to provide a tailored and specialized solution for each individual application:

- ✓ Heating
- ✓ Cooling
- ✓ Domestic hot water
- ✓ Air renewal and purification
- ✓ Dehumidification

Decentralization

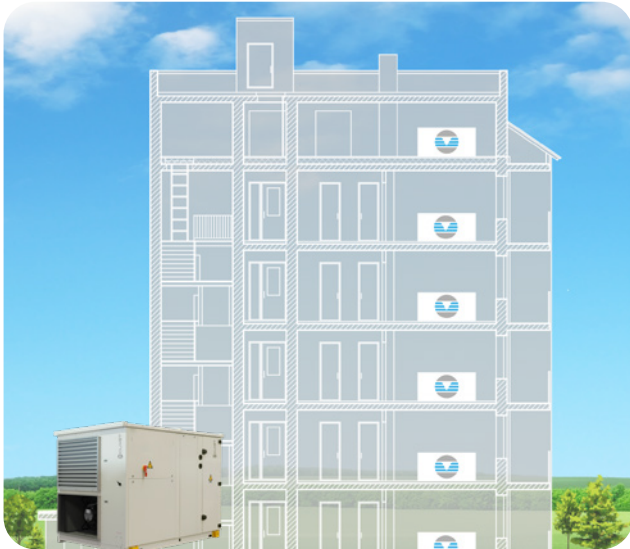

Example of floor-based decentralization

In developing Clivet products and systems, great attention was given to how to rationalize each choice in terms of design and construction, which could affect the system's running costs and environmental impact for its entire life cycle.

Many years ago, Clivet successfully developed the principle of generating energy as close as possible to where it needs to be used:

- ✓ Modular systems that are active only where and when required
- ✓ Reduction or complete elimination of auxiliary consumption (for instance, pumping energy)
- ✓ Stand-alone system
- ✓ Easy to maintain and handle
- ✓ Adapts to the needs of the system

Integrated Systems



Clivet designs its systems by integrating all the services required for each application.

The system's elements, optimized and industrially processed to work together, guarantee the highest efficiency and reliability.

- ✓ Simplified design and installation
- ✓ Lower investment costs
- ✓ Quality of the systems
- ✓ Guaranteed performance

Digital Solution

In residential, commercial and industrial buildings, the air conditioning system is the main source of energy consumption, accounting for almost half of the building's total consumption. There is an increasing need for an energy transition as the effect of climate change is growing.

Clivet has decided to play a key role by designing and promoting new technological solutions to improve the efficiency of buildings and significantly reduce its carbon footprint for increasingly sustainable installations.



Optimization system for the commercial and industrial sector

Optimizing the operation of HVAC systems allows the efficiency of commercial and industrial plants to be maximized in various working conditions, guaranteeing the reduction of energy consumption and ensuring continuity of operation in the production and distribution of thermo-cooling energy.

Clivet's **INTELLIPLANT** solution manages all the elements of medium and large hydronic systems, guaranteeing the best operating conditions for the lowest possible energy consumption.

Developed entirely by Clivet specialists, INTELLIPLANT makes it possible to achieve the maximum efficiency of the system and the units it interfaces with, thanks to algorithms derived from Clivet know-how that make better use of the machine control logics than the most common generalist solutions on the market.

SHEEN NA



Reversible heat pump

Air cooled
Inverter Technology
Outdoor installation

Capacity 20 TON

**WiSAN-YSE1 NA
30.2**

- ✓ **Reversible Heat Pump Technology.** Capable of producing hot or cold water based on the season.
- ✓ **High Reliability Design.** Inverter Scroll compressor ensures efficient and reliable operation. DC Inverter fans offer superior airflow and energy efficiency. Two independent circuits provide redundancy and enhanced reliability.
- ✓ **Highly Sustainable Ecological Refrigerant.** R32 with a Global Warming Potential of 675, reducing environmental impact.
- ✓ **Industry-Leading Efficiency.** Full inverter scroll technology guarantees performance at full and partial load to adapt to the needs of the plant. IPLV (Integrated Part Load Value) up to 20.1, maximizing seasonal performance.
- ✓ **Ultra-Quiet Operation.** Our super-silenced version reduces noise levels, ensuring a quieter environment. Configurable sound emissions reduce the fans speed.
- ✓ **Wide Operating Envelope.** Delivers outlet water temperatures up to 149°F and operates in outdoor temperatures as low as -22°F.
- ✓ **Faster, More Efficient Defrosting.** A special hydrophilic coil treatment shortens defrost cycles, ensuring uninterrupted performance and efficiency.
- ✓ **System scalability up to 160 Tons.** Modular operation up to 8 units in a cascade setup.

Functions and Features



Heat pump



Air cooled



Outdoor installation



R-32



Hermetic scroll



Electronic expansion valve



ECOBREEZE



Full inverter

Dimensions and Clearances

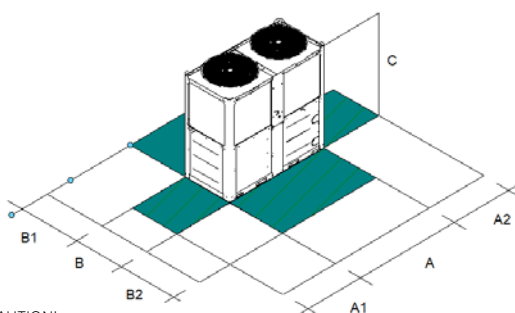

CAUTION!

For trouble-free operation of the unit it is essential to maintain the safety distances indicated by the green areas.

Size	▶▶ WiSAN-YSE1 NA	30.2
A - Length	in	78.74
B - Width	in	37.8
C - Height	in	74.02
A1	in	59.1
A2	in	59.1
B1	in	59.1
B2	in	59.1
Operating weight	lbs	1,193

The above mentioned data refer to standard units. For all other configurations, please refer to the dedicated technical bulletin.

Versions and Configurations

SUPPLY VOLTAGE:

US1 208-230/3~/60 Supply voltage (Standard)

ENERGY VERSION:

EXC Excellence version

EXTERNAL SECTION FAN CONSUMPTION REDUCTION:

VENDC DC high efficiency fan (Standard)

Technical Data

SIZE	▶▶ WiSAN-YSE1 NA	30.2
Cooling Capacity	(1) ton	20.0
Total power input	(1) kW	23.4
EER	(1) BTU / (Wh)	10.2
IPLV	(1) BTU / (Wh)	20.1
Heating Capacity	(2) MBH	256
Total power input	(2) kW	22.1
COP	(2) kW / kW	3.40
Refrigeration circuits	Nr	2
N° of compressors	Nr	2
Type of compressors	-	INVERTER SCROLL
Refrigerant	-	R-32
Standard power supply	V	208-230/3~/60
SCCR	kA	5
Sound power level cooling (SC)	(3) dB (A)	83

(1) Data: User side heat exchanger water 54 °F / 44 °F; Outdoor Air 95 °F

(2) Data: User side heat exchanger water 110 °F / 120 °F; Outdoor air 47 °F d.b. / 43 °F w.b.

(3) Sound power calculated on the basis of measurements made in accordance with UNI EN ISO 9614-2

Accessories

- BCACF** Copper / aluminium condenser coil with acrylic lining
- CMSC13X** Serial communication module for Modbus TCP/IP, BACnet IP, BACnet MSTP supervisor
- AVIBX** Anti-vibration mount support
- HYGU1VI** User side hydronic group with 1 inverter pump
- TCDC** Condensate collection pan with electric heater

Accessories whose code ends with "X" are supplied separately

SPINCHILLER4 NA

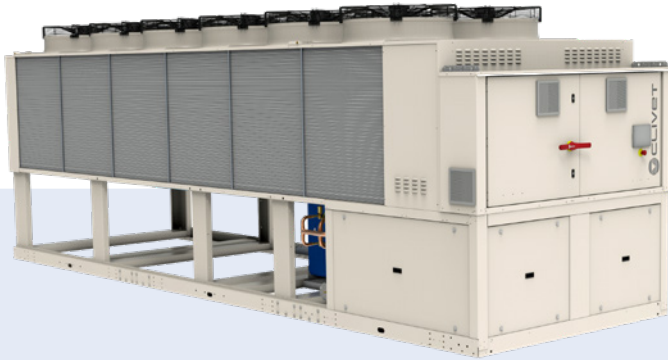

Reversible heat pump

Air cooled

Outdoor installation

Capacity from 67.7 to 126 TON

WSAN-YSC4 NA

90.4÷175.4

- ✓ **Reversible Heat Pump Technology.** Capable of producing hot or cold water based on the season.
- ✓ **High Reliability Design.** Multiscroll technology optimizes performance with precise load adjustments, delivering consistent comfort and efficiency. EC axial fans offer superior airflow and energy efficiency. Two independent circuits provide redundancy and enhance reliability.
- ✓ **Highly Sustainable Ecological Refrigerant.** R32 with a Global Warming Potential of 675, reducing environmental impact.
- ✓ **Industry-Leading Efficiency.** High performance at full and partial load to adapt to the needs of the plant. IPLV (Integrated Part Load Value) up to 17.4, maximizing seasonal performance.
- ✓ **Ultra-Quiet Operation.** Our super-silenced version reduces noise levels, ensuring a quieter environment.
- ✓ **Faster, More Efficient Defrosting.** A special hydrophilic coil treatment shortens defrost cycles, ensuring uninterrupted performance and efficiency.
- ✓ **Optimized Modular Operation.** Cascade capability up to 7 units in a cascade setup.
- ✓ **Full Range of Accessories.** Comprehensive accessory options tailored for the North American market.

Functions and Features



Heat pump



Air cooled



Outdoor installation



R-32



Hermetic scroll



Electronic expansion valve



ECOBREEZE



HydroPack

Dimensions and Clearances

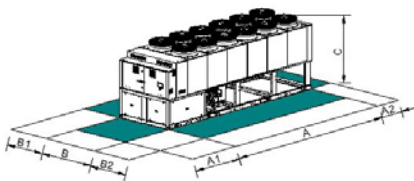

Size	▶▶ WSAN-YSC4 NA	90.4	100.4	110.4	120.4	130.4	145.4	160.4	175.4
A - Length	in	161.9	161.9	161.9	161.9	161.9	200.4	200.4	200.4
B - Width	in	87.7	87.7	87.7	87.7	87.7	87.7	87.7	87.7
C - Height	in	99.5	99.5	99.5	99.5	99.5	99.5	99.5	99.5
A1	in	59.1	59.1	59.1	59.1	59.1	59.1	59.1	59.1
A2	in	27.6	27.6	27.6	27.6	27.6	27.6	27.6	27.6
B1	in	47.2	47.2	47.2	47.2	47.2	47.2	47.2	47.2
B2	in	47.2	47.2	47.2	47.2	47.2	47.2	47.2	47.2
Operating weight	lbs	6,241	6,338	6,415	6,735	6,971	7,840	8,167	8,440

The above mentioned data refer to standard units. For all other configurations, please refer to the dedicated technical bulletin.

CAUTION!

For trouble-free operation of the unit it is essential to maintain the safety distances indicated by the green areas.

Versions and Configurations

SUPPLY VOLTAGE:

4606H	460/3/60 Supply voltage (Standard)
5756H	573/3/60 Supply voltage

ACOUSTIC CONFIGURATION:

SC	Acoustic configuration with compressor soundproofing (Standard)
EN	Super-silenced acoustic configuration

EXTERNAL SECTION FAN CONSUMPTION REDUCTION:

CREFB	Device for fan consumption reduction of the external section, ECOBREEZE type (Standard)
--------------	---

Technical Data

SIZE		▶▶ WSAN-YSC4 NA	90.4	100.4	110.4	120.4	130.4	145.4	160.4	175.4
Cooling Capacity	(1)	ton	67.7	73.4	79.1	84.1	92.1	103	115	126
Total power input	(1)	kW	77.3	87.1	95.8	104	114	125	139	157
EER	(1)	BTU / (Wh)	10.5	10.1	9.91	9.69	9.72	9.89	9.92	9.64
IPLV	(1)	BTU / (Wh)	17.4	17.2	16.9	16.6	16.7	17.1	17.0	16.6
Heating Capacity	(2)	MBH	813	881	949	1,052	1,154	1,314	1,451	1,588
Total power input	(2)	kW	81.3	88.0	96.3	104	112	128	142	160
COP	(2)	kW / kW	2.93	2.94	2.89	2.97	3.03	3.01	2.99	2.91
Refrigeration circuits		Nr					2			
N° of compressors		Nr					4			
Type of compressors		-					SCROLL			
Refrigerant		-					R-32			
Standard power supply		V					460/3~/60			
SCCR		kA	65	65	65	65	65	65	65	65
Sound power level cooling (SC)	(3)	dB(A)	90	91	91	91	91	92	93	93
Sound power level cooling (EN)	(3)	dB(A)	87	87	87	87	88	89	89	90

(1) Data: User side heat exchanger water 54 °F / 44 °F; Outdoor Air 95 °F

(2) Data: User side heat exchanger water 110 °F / 120 °F; Outdoor air 47 °F d.b. / 43 °F w.b.

(3) Sound power calculated on the basis of measurements made in accordance with UNI EN ISO 9614-2

Accessories

CCCA	Copper / aluminium condenser coil with acrylic lining
CCCA1	Condenser coil with Aluminium Energy Guard DCC treatment
PFGP	Soundproofing paneling of the pumping unit
IVFDT	Inverter driven variable flow-rate user side control depending on the temperature differential
CSVX	Couple of manually operated shut-off valves
IFWX	Steel mesh strainer on the water side
CMSC9	Serial communication module for Modbus supervisor
CMSC11	Serial communication module for BACnet-IP supervisor
CMSC12	Serial communication module for BACnet-MSTP supervisor
RCMRX	Remote control via microprocessor control
RE-25	Electrical panel antifreeze protection for min. outdoor temperature down to -25°C
RE-39	Electrical panel antifreeze protection for min. outdoor temperature down to -39 °C
DML4-20	Demand limit with 4-20 mA
DML0-10	Demand limit with 0-10 V

CREFBH	High static pressure ecobreeze system
ECS	ECOSHARE function for the automatic management of a group of units
SPC1	Set-point compensation with 4-20 mA
SCP4	Set-point compensation with 0-10 V
PSX	Mains power supply
AMMX	Rubber antivibration mounts
PGFC	Finned coil protection grill
PGCCH	Anti-hail protection grilles
1PM	Hydropack user side with 1 on/off pump
1PMV	Hydropack user side with 1 inverter pump
1PMH	Hydropack user side with 1 high static pressure on/off pump
1PMVH	Hydropack user side with 1 high static pressure inverter pump
1P1SB	Hydropack user side with 1+1 on/off pump
1P1SBV	Hydropack user side with 1+1 inverter pump
1PAPS	Hydropack user side with 1+1 high static pressure on/off pump
1PAPSV	Hydropack user side with 1+1 high static pressure inverter pump

Accessories whose code ends with "X" are supplied separately

SPINCHILLER4 PL NA

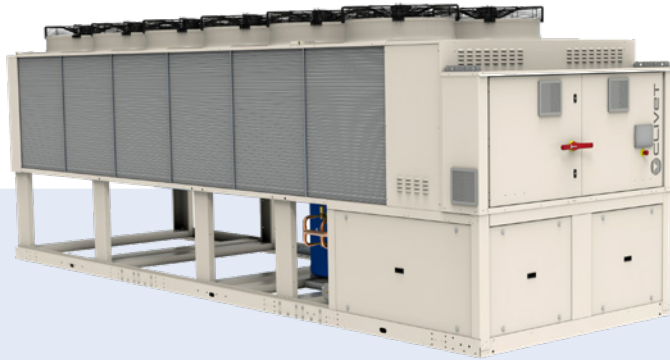

Polyvalent heat pump

Air cooled

Outdoor installation

Capacity from **67.7 to 126 TON**

WSAN-YSC4 PL NA

90.4÷175.4

- ✓ **Polyvalent Heat Pump Technology.** Capable of producing hot and cold water at the same time.
- ✓ **High Reliability Design.** Multiscroll technology optimizes performance with precise load adjustments, delivering consistent comfort and efficiency. EC axial fans offer superior airflow and energy efficiency. Two independent circuits provide redundancy and enhance reliability
- ✓ **Highly Sustainable Ecological Refrigerant.** R32 with a Global Warming Potential of 675, reducing environmental impact.
- ✓ **Industry-Leading Efficiency.** High performance at full and partial load to adapt to the needs of the plant. Total Efficiency Ratio (TER) up to 7.1 for outstanding energy savings. IPLV (Integrated Part Load Value) up to 17.4, maximizing seasonal performance.
- ✓ **Ultra-Quiet Operation.** Our super-silenced version reduces noise levels, ensuring a quieter environment.
- ✓ **Smart Defrost Technology.** Our advanced defrost algorithm, reduces energy loss by 33% compared to traditional defrost. A special hydrophilic coil treatment shortens defrost cycles, ensuring performance and efficiency.
- ✓ **Optimized Modular Operation.** Cascade capability up to 7 units in a cascade setup.
- ✓ **Full Range of Accessories.** Comprehensive accessory options tailored for the North American market.

Functions and Features



Heat pump



Air cooled



Outdoor installation



R-32



Hermetic scroll



Electronic expansion valve



ECOBREEZE



HydroPack

Dimensions and Clearances

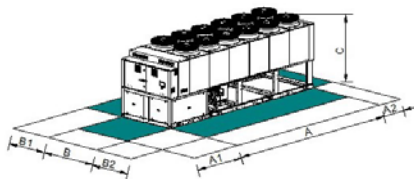

Size	▶▶ WSAN-YSC4 PL NA	90.4	100.4	110.4	120.4	130.4	145.4	160.4	175.4
A - Length	in	161.9	161.9	161.9	161.9	161.9	200.4	200.4	200.4
B - Width	in	87.7	87.7	87.7	87.7	87.7	87.7	87.7	87.7
C - Height	in	99.5	99.5	99.5	99.5	99.5	99.5	99.5	99.5
A1	in	59.1	59.1	59.1	59.1	59.1	59.1	59.1	59.1
A2	in	27.6	27.6	27.6	27.6	27.6	27.6	27.6	27.6
B1	in	47.2	47.2	47.2	47.2	47.2	47.2	47.2	47.2
B2	in	47.2	47.2	47.2	47.2	47.2	47.2	47.2	47.2
Operating weight	lbs	6,592	6,834	6,834	7,278	7,560	8,489	8,816	9,221

The above mentioned data refer to standard units. For all other configurations, please refer to the dedicated technical bulletin.

CAUTION!

For trouble-free operation of the unit it is essential to maintain the safety distances indicated by the green areas.

Versions and Configurations

SUPPLY VOLTAGE:

4606H	460/3/60 Supply voltage (Standard)
5756H	573/3/60 Supply voltage

EXTERNAL SECTION FAN CONSUMPTION REDUCTION:

CREFB	Device for fan consumption reduction of the external section, ECOBREEZE type (Standard)
--------------	---

STRUCTURAL CONFIGURATION:

4T	Configuration for 4-pipe system
-----------	---------------------------------

ACOUSTIC CONFIGURATION:

SC	Acoustic configuration with compressor soundproofing (Standard)
EN	Super-silenced acoustic configuration

Technical Data

SIZE		WSAN-YSC4 PL NA	90.4	100.4	110.4	120.4	130.4	145.4	160.4	175.4
Cooling 100% - Heating 0%										
Cooling Capacity	(1)	ton	67.7	73.4	79.1	84.1	92.1	103	115	126
Total power input	(1)	kW	77.3	87.1	95.8	104	114	125	139	157
EER	(1)	BTU / (Wh)	10.5	10.1	9.91	9.69	9.72	9.89	9.92	9.64
IPLV	(1)	BTU / (Wh)	17.4	17.2	16.9	16.6	16.7	17.1	17.0	16.6
Cooling 0% - Heating 100%										
Heating Capacity	(2)	MBH	839	906	975	1,078	1,179	1,343	1,489	1,636
Total power input	(2)	kW	81.3	88.2	95.9	102	111	127	140	159
COP	(2)	kW / kW	3.02	3.01	2.98	3.08	3.12	3.11	3.11	3.02
Cooling 100% - Heating 100%										
Cooling Capacity	(3)	ton	65.9	71.5	77.1	82.0	90.1	101	112	123
Heating Capacity	(3)	MBH	1,025	1,116	1,209	1,292	1,415	1,594	1,766	1,935
Total power input	(3)	kW	75.1	82.4	90.5	98.0	106	120	134	146
TER	(3)	kW / kW	7.08	7.02	6.91	6.80	6.88	6.86	6.83	6.84
Refrigeration circuits		Nr					2			
N° of compressors		Nr					4			
Type of compressors		-					SCROLL			
Refrigerant		-					R-32			
Standard power supply		V					460/3~/60			
SCCR		kA	65	65	65	65	65	65	65	65
Sound power level cooling (SC)	(4)	dB(A)	90	91	91	91	91	92	93	93
Sound power level cooling (EN)	(4)	dB(A)	87	87	87	87	88	89	89	90

(1) Data: User side heat exchanger water 54 °F / 44 °F; Outdoor Air 95 °F

(2) Data: User side heat exchanger water 110 °F / 120 °F; Outdoor air 47 °F d.b. / 43 °F w.b.

(3) Water hot side heat exchanger *120°F; Water to cold side heat exchanger *144 °F

(4) Sound power calculated on the basis of measurements made in accordance with UNI EN ISO 9614-2

The above mentioned data refer to standard units. For all other configurations, please refer to the dedicated technical bulletin.

Accessories

CCCA	Copper / aluminium condenser coil with acrylic lining
CCCA1	Condenser coil with Aluminium Energy Guard DCC treatment
PFGP	Soundproofing paneling of the pumping unit
IVFCDT	Variable flow rate control cooling side by inverter according to the temperature differential
IVFHDT	Variable flow rate control heating side by inverter according to the temperature differential
CSVX	Couple of manually operated shut-off valves
IFWX	Steel mesh strainer on the water side
CMSC9	Serial communication module for Modbus supervisor
CMSC11	Serial communication module for BACnet-IP supervisor
CMSC12	Serial communication module for BACnet-MSTP supervisor
RCMRX	Remote control via microprocessor control
RE-25	Electrical panel antifreeze protection for min. outdoor temperature down to -25 °C
RE-39	Electrical panel antifreeze protection for min. outdoor temperature down to -39 °C
DML4-20	Demand limit with 4-20 mA
DML0-10	Demand limit with 0-10 V
CREFBH	High static pressure ecobreeze system
ECS	ECOSHARE function for the automatic management of a group of units
SPC1	Set-point compensation with 4-20 mA

Accessories whose code ends with "X" are supplied separately

SCP4	Set-point compensation with 0-10 V
PSX	Mains power supply
AMMX	Spring antivibration mounts
PGFC	Finned coil protection grill
PGCCH	Anti-hail protection grilles
1PMHS	Hydropack for hot side with 1 on/off pump
1PMHSH	Hydropack for hot side with 1 high static pressure on/off pump
1PMHSV	Hydropack for hot side with 1 inverter pump
1PMHSVH	Hydropack for hot side with 1 high static pressure inverter pump
1+1PMHS	Hydropack for hot side with 1+1 on/off pump
1+1PMHSH	Hydropack for hot side with 1+1 high static pressure on/off pump
1+1PMHSV	Hydropack for hot side with 1+1 inverter pump
1+1PMHSVH	Hydropack for hot side with 1+1 high static pressure inverter pump
1PMCS	Hydropack for cold side with 1 on/off pump
1PMCSH	Hydropack for cold side with 1 high static pressure on/off pump
1PMCSV	Hydropack for cold side with 1 inverter pump
1PMCSVH	Hydropack for cold side with 1 high static pressure inverter pump
1+1PMCS	Hydropack for cold side with 1+1 on/off pump
1+1PMCSH	Hydropack for cold side with 1+1 high static pressure on/off pump
1+1PMCSV	Hydropack for cold side with 1+1 inverter pump
1+1PMCSVH	Hydropack for cold side with 1+1 high static pressure inverter pump

WiSAN-YMD1 NA

MODULAR UNIT



Reversible heat pump

Air cooled
Inverter Technology
Outdoor installation

Capacity 28.6 TON
WiSAN-YMD1 NA
40.2

- ✓ **Reversible Heat Pump Technology.** Capable of producing hot/cold water to satisfy the needs of residential and commercial buildings.
- ✓ **High Reliability Design.** Inverter Scroll compressor ensures efficient and reliable operation. DC Inverter fans offer superior airflow and energy efficiency. Two refrigerant circuits provide redundancy and enhanced reliability.
- ✓ **Highly Sustainable Ecological Refrigerant.** R32 with a Global Warming Potential of 675, reducing environmental impact.
- ✓ **Industry-Leading Efficiency.** Full inverter scroll technology guarantees performance at full and partial load to adapt to the needs of the plant. IPLV (Integrated Part Load Value) up to 18.5, maximizing seasonal performance.
- ✓ **Wide Operating Envelope.** Delivers outlet water temperatures up to 140°F and operates in outdoor temperatures as low as -13°F.
- ✓ **High Modularity.** Possibility of coupling up to 16 units in a local network, with 2 groups of 8 units hydraulically connected, designed to minimize the overall footprint.
- ✓ **Plug and Play solution.** Multiple units can be lifted and positioned as pre-assembled skids, easily interconnected on site, minimizing installation time and downtime.
- ✓ **4-pipe configuration.** With the Intelliplant system and the integrated 4-pipes kit, the production of hot and cold water can also be produced simultaneously. The Intelliplant manages the operating mode of each unit according to the cooling/heating load required by the building.

Functions and Features



Heat pump



Air cooled



Outdoor installation



R-32



Hermetic scroll



Electronic expansion valve



ECOBREEZE



Full inverter



Intelliplant

Dimensions and Clearances

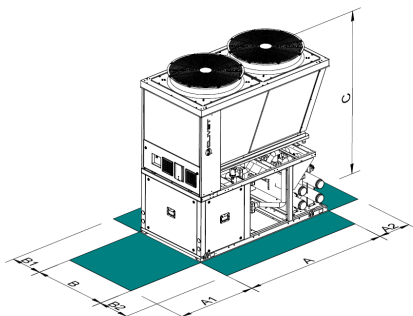

Size	▶ WiSAN-YMD1 NA	40.2
A - Length	in	87.58
B - Width	in	46.2
C - Height	in	92.26
A1	in	47.99
A2	in	19.69
B1	in	19.69
B2	in	19.69
Operating weight	lbs	1,940

The above mentioned data are referred to standard units for the constructive configurations indicated.

CAUTION!
For trouble-free operation of the unit it is essential to maintain the safety distances indicated by the green areas.

Versions and Configurations

SUPPLY VOLTAGE:

4606H 460/3/60 Supply voltage (Standard)

ACOUSTIC CONFIGURATION

SC Acoustic configuration with compressor soundproofing (Standard)

LN Silenced acoustic configuration

EN Super-silenced acoustic configuration

DRAIN PAN

TCDC Drain pan with electrical heater (Standard)

EXTERNAL SECTION FAN CONSUMPTION REDUCTION:

VENDC DC high efficiency fan (Standard)

WATER FITTINGS USER SIDE EXCHANGER

- Water fittings for modular unit: not required (Standard)

AMOD2MA Water fittings for modular unit 2 pipes with manual valves

AMOD2MO Water fittings for modular unit 2 pipes with motorized valves

AMOD4MO Water fittings for modular unit 4 pipes with motorized valves

ELECTRICAL PANEL

MOB Serial port RS485 with modbus protocol (Standard)

Technical Data

SIZE	▶▶ WISAN-YMD1 NA		40.2
Cooling Capacity	(1)	ton	28.6
Total power input	(1)	kW	37.2
EER	(1)	BTU / (Wh)	9.22
IPLV	(1)	BTU / (Wh)	18.5
Heating Capacity	(2)	MBH	382
Total power input	(2)	kW	36.6
COP	(2)	kW / kW	3.06
Refrigeration circuits		Nr	2
N° of compressors		Nr	2
Type of compressors		-	INVERTER SCROLL
Refrigerant		-	R-32
Standard power supply		V	460/3~/60
SCCR		kA	65
Sound power level cooling (SC)	(3)	dB(A)	87

(1) Data: User side heat exchanger water 54 °F / 44 °F; Outdoor Air 95 °F

(2) Data: User side heat exchanger water 110 °F / 120 °F; Outdoor air 47 °F d.b. / 43 °F w.b.

(3) Sound power calculated on the basis of measurements made in accordance with UNI EN ISO 9614-2

Accessories

CCCA	Copper / aluminium condenser coil with acrylic lining
CCCA1	Condenser coil with Aluminium Energy Guard DCC treatment
CMSC13X	Serial communication module for Modbus TCP/IP, BACnet IP, BACnet MSTP supervision system
PGFC	Finned coil protection grill
EWHP	User side water piping antifreeze electric heaters
IFWX	Steel mesh strainer on the water side
AMMSX	Anti-seismic spring antivibration mounts
INTELX	Intelliplant Management
STX	Temperature sensors

Accessories whose code ends with "X" are supplied separately

INTELLIPLANT

Optimization system and modular heat pump supervisor



- ✓ **Monitoring and control** of hydronic chiller units, reversible heat pumps and multifunctional units.
- ✓ **Workload distribution:** the heating and cooling load is equally distributed between the various units, making the most of their operation in partial load mode.
- ✓ **Centralized management:** professional multi-site cloud platform for unified and simplified control allows the various systems to be monitored and managed from a single interface.

System Manager

The INTELLIPLANT system allows you to efficiently and continuously manage the hydronic units on the local operator panel and on the remote interface on a computer, smartphone or tablet. Thanks to the values acquired in real time from the system, advanced control logics enable efficient management of thermal loads based on real system demand, constantly monitoring the system conditions and selecting unit activation, either based on the most performing activation sequence or by balancing the operating hours.

- ✓ Monitoring and control of hydronic chiller units, reversible heat pumps and multifunctional units
- ✓ Primary circuit management of 2-pipe and 4-pipe systems
- ✓ Integration with BMS/BAS through open protocols

System Type Management

SYSTEM TYPE	UNITS IN-BUILT CONTROL	INTELLIPLANT
2 PIPES (no DHW)	✓	
2 PIPES + DHW		✓
4 PIPES (no DHW)		✓
2 PIPES (no DHW)		✓
2 PIPES + DHW		✓
4 PIPES (no DHW)		✓

Graphic Interface

Plant Schematic

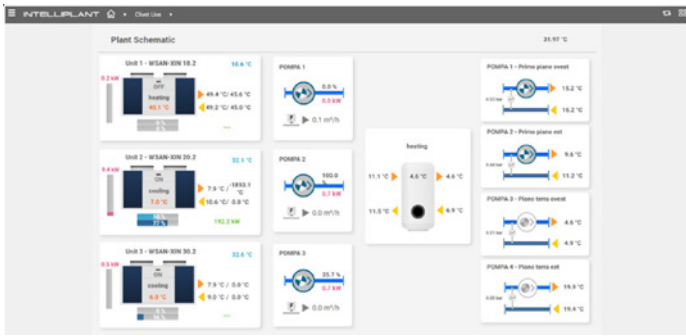

The page offers a customized graphic representation where each area can be checked:

- ✓ operation status;
- ✓ real-time values of key operating parameters such as temperature and humidity;
- ✓ presence of alarms that must be promptly reported to the system supervisor/manager.

The user can access detailed parameters specific to the area or individual units.

Unit

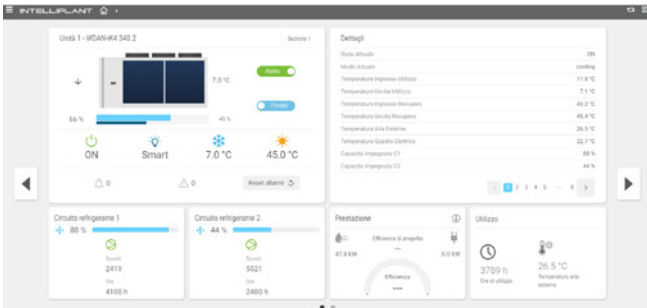

The following basic information is displayed for each unit:

- ✓ graphical model of the unit with dynamic representation of the operating state;
- ✓ operating status of the unit and buttons for quick actions;
- ✓ details of component status (fans, compressors, etc.);
- ✓ list of parameters and their values in real time.

Plant Dashboard

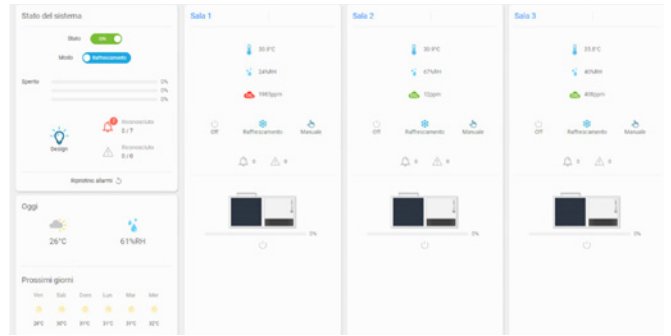

The main page of the system provides an overview with reports for all areas:

- ✓ system operational status and quick action buttons;
- ✓ percentage and mode of operation of individual units, broken down by areas;
- ✓ maintenance status resulting from the preventive analysis of each individual unit;
- ✓ priority and second-level alarms;
- ✓ current day's weather and forecast for the next 7 days.

Predictive Maintenance

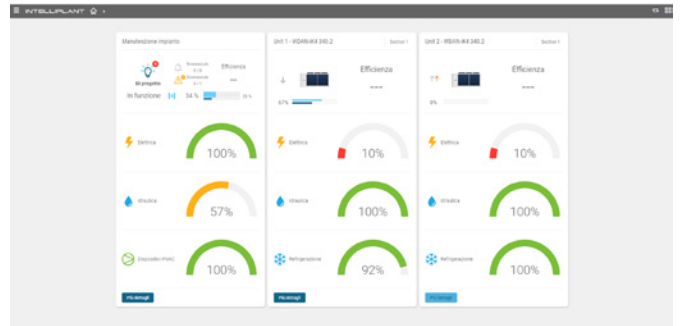

INTELLIPLANT helps to develop the concept of maintenance from traditional "scheduled routine maintenance" to the more advanced idea of "condition based maintenance", i.e. maintenance customized per event according to its operational status, applicable to the most significant situations affecting refrigeration thermal unit components.

Data contained in this catalogue are not binding and may be changed by the Manufacturer without notice.
No part of this publication may be reproduced.
Updated data available on **www.clivet.us**

For 35 years, we've been
designing technologies
that make comfort sustainable
for people and the planet.

CLIVET S.p.A.

Via Camp Lonc 25, Z.I. Villapaiera 32032
Feltre (BL) - Italy

www.clivet.us

**FOR ALL NORTH AMERICA INQUIRIES CONTACT
MASTER DISTRIBUTOR.**

**THE PRODUCTS INSIDE THIS CATALOGUE
ARE DISTRIBUTED BY MASTER DISTRIBUTOR,
MITS AIRCONDITIONING INC., IN NORTH AMERICA.**

Mits Airconditioning Inc.,

1608 Bonhill Road Mississauga, ON L5T 1C7 Canada

Email: clivet@mitsair.com

Canada: 1-800-567-2221

US: 1-888-567-2227

Fax: 905-564-2205