

10.6 Connections performed by Customer

All the cables supplied and connected on site should be in double or reinforced insulation with reference to the maximum volatge of the unit: 230 V.

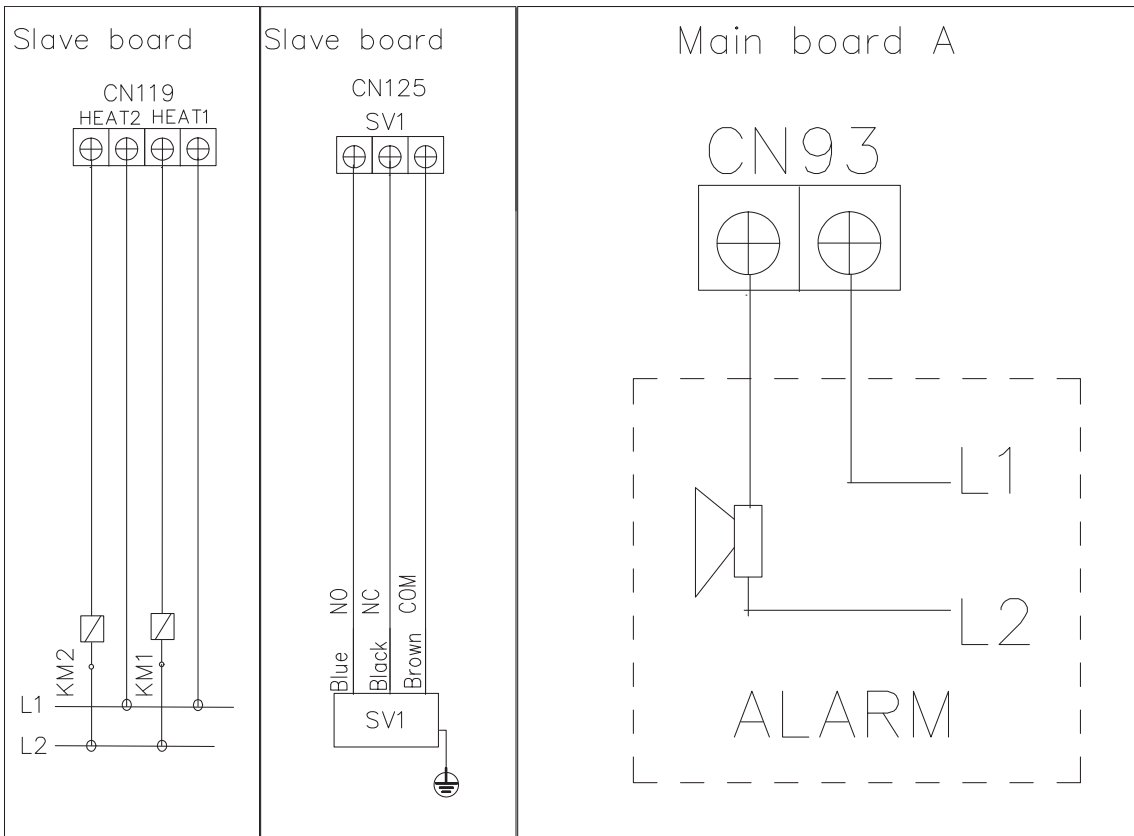

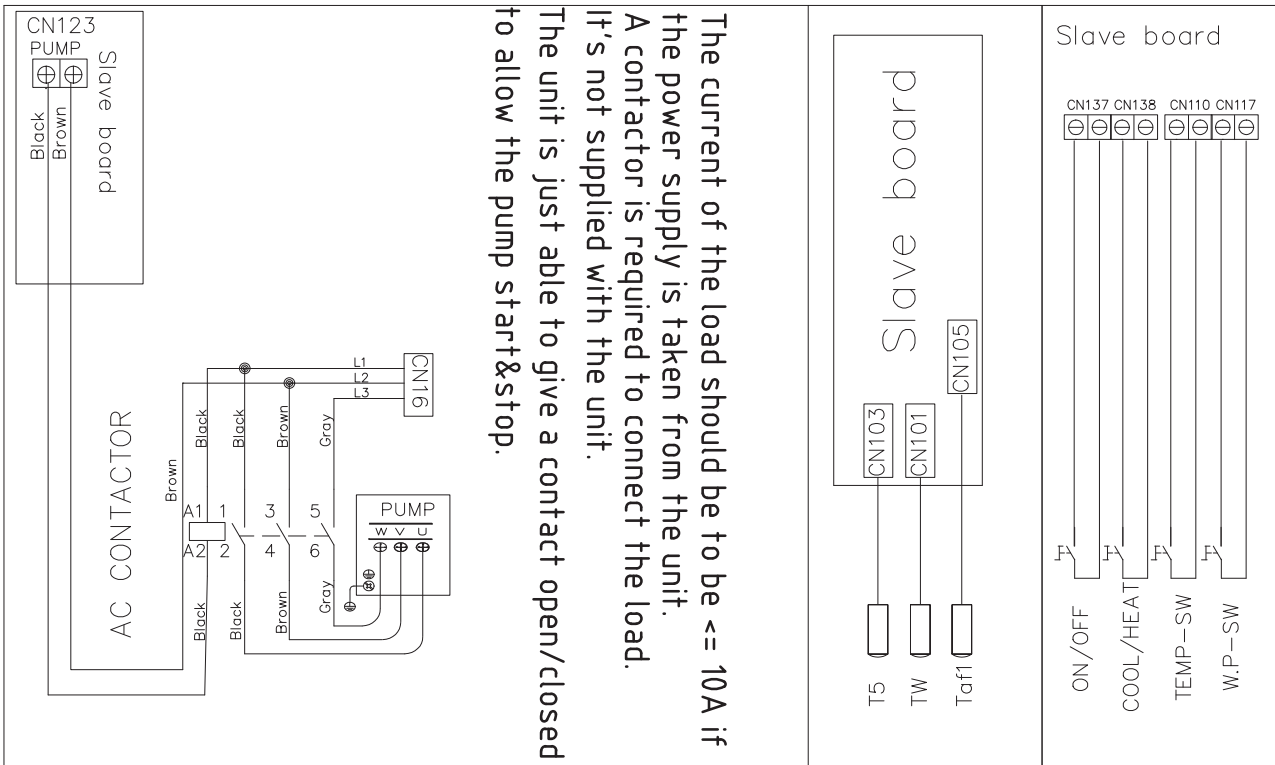
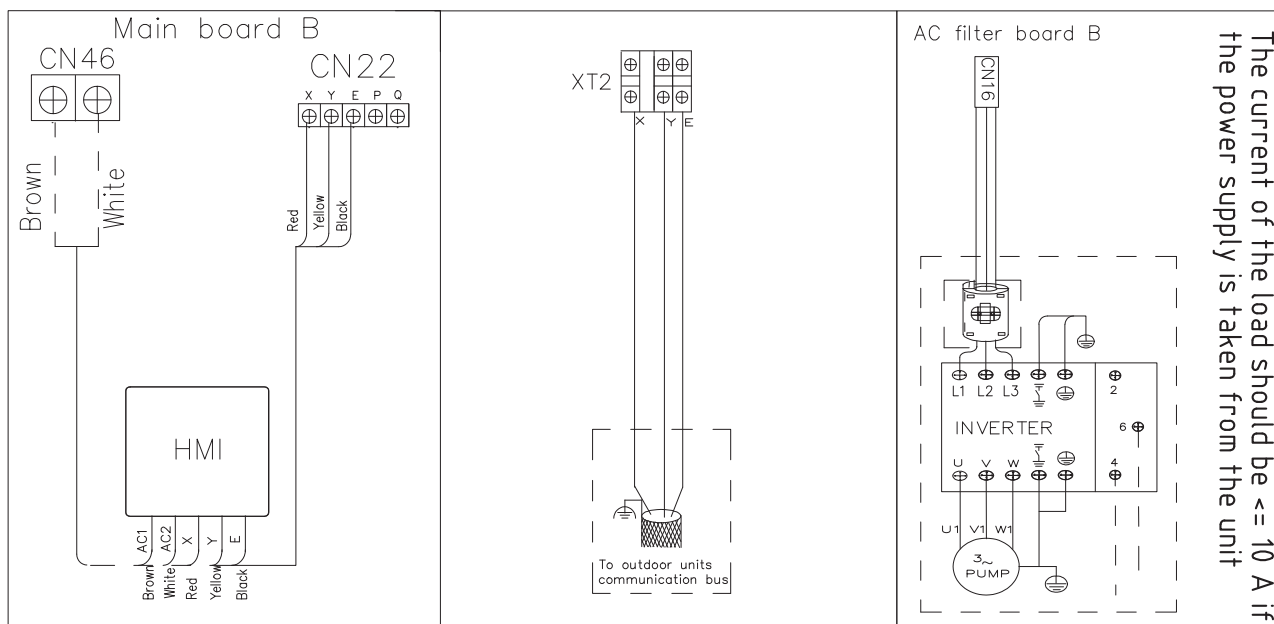

*Note: If the HMI is installed at more than 10m from the unit, a dedicated cable for control is required in the installation (the cable supplied with the unit is long 10 m). The power supply should be done by an external receptacle through the transformer supplied with the unit or equivalent.

i The cable supplied for the control should be in double or reinforced insulation.

Wiring diagram

i Refer to the unit's diagram for the complete wiring diagram.

10.7 Remote control of the unit

With S1_1 ON, the unit is controlled remotely.

The wired controller is disabled.

ON/OFF status controlled by the On/Off input (CN137 on expansion slave board – 12VCC):

- input ON = unit ON
- input OFF = unit OFF

Heat/Cool mode controlled by the Heat/Cool input (CN138 on expansion slave board – 12VCC):

- On = heating
- Off = cooling

Double setpoint controlled by TEMP-SW (CN110 on expansion slave board – 12VCC):

- input ON = 2nd setpoint
- input OFF = Main setpoint
- this function must also be enabled from the wired controller.

With the units in modular configuration, remote control must be applied to the master unit, which transmits it to the slave units.

After setting S5_3, disconnect and reconnect the power supply to confirm the change.

10.8 TW probe

- The total system supply water control probe is in a plastic bag with a 10 m long cable inside the electrical panel and must be connected to the master unit on the expansion board at terminal CN 101 (3,3V DC).
- With the unit in modular configuration, the TW probe of the master unit must be re-installed as far away as possible on the common supply line of the system but before meeting any load. Use the additional probe support in the electrical panel.

Note: See also the dedicated chapter for further details.

10.9 Taf1 probe

- The domestic hot water antifreeze protection probe is in a plastic bag with a 10 m long cable inside the electrical panel.
- To connect probe Taf1, connect to the expansion board (terminal CN 105 - 3,3V DC). Install the probe on the discharge pipe from the domestic hot water inertial tank.

10.10 T5 probe

- The temperature probe that switches from the system to domestic hot water is in a plastic bag with a 10 m long cable inside the electrical panel on the expansion board (terminal CN 103 - 3,3V DC)

10.11 Backup heater control HEAT1 - KM1

HEAT 1 is the backup heater control for the heating system.

The function only applies to heat pump operation.

The heater can be used:

- as auxiliary anti-freeze protection. This function is useful when the unit is expected to be switched OFF for long periods with low outdoor air temperatures. The heaters are activated for water temperatures below 6°C.
- Integration with the heat pump in the following cases:
 - as a replacement for the heat pump if it is shut down due to failure or protection.
 - active in case of manual forcing.
 - with low air temperature, as integration with the heat pump.
 - to extend the operation limits, as integration with the heat pump.

The unit cannot supply the HEAT1 load directly and therefore a dedicated power supply and a supporting contactor are required. The unit is just capable of handling activation of this backup heater.

HEAT1 is to be connected to the expansion board (terminal CN119 HEAT1).

The unit's contactor and power supply must be sized according to the capacity of the backup heater in accordance with local regulations.

Refer to the Service manual for configuration.

10.12 Backup heater control HEAT2

HEAT 2 is the backup heater control for DHW.

The heater can be used:

- as a replacement for the heat pump if it is shut down due to failure or protection.
- active in case of manual forcing.
- with low air temperature, as integration with the heat pump.
- to extend the operation limits, as integration with the heat pump.
- when the DHW tank temperature is too low, as a replacement for the heat pump.
- in case of frequent compressor ON-OFF cycles, as a replacement for the heat pump.

The unit cannot supply HEAT2 directly and therefore a dedicated power supply and a supporting contactor are required. The unit is just capable of handling activation of this backup heater.

HEAT2 is to be connected to the expansion board (terminal CN119 HEAT2).

The unit's contactor and power supply must be sized according to the capacity of the backup heater in accordance with local regulations.

Refer to the Service manual for configuration.

10.13 Alarm signal

ALARM

- Closed contact with the unit in alarm.
- Contact on Main Board A: CN93.
- The alarm device, if audible, must be supplied by the installer.

10.14 Compressor running signal

HL1

- Closed contact with at least one compressor switched on.
- Contact on slave board: CN121.
- The alarm device, if audible, must be supplied by the installer.

10.15 External pump control on/off

PUMP-N

- If a unit is supplied without a circulation pump, control the external pump as shown in the wiring diagram.
- Use an auxiliary relay to enable the power supply contact on expansion board: CN 123.
- The power supply can be taken from filter board B (CN16) if the circulation pump does not exceed 10 A maximum current consumption, otherwise a dedicated power supply is required.

Note:

If the power supply is taken from the connection (CN 16 - 208-230 V/3~60 Hz), consider the corresponding electrical data increase due to the pump consumption in sizing main cables and electrical protections.

10.16 External pump control PUMP-INV

- If a unit is supplied without a circulation pump and you want it to be driven at variable speed, you can control the external inverter as shown in the diagram.
- The power supply can be taken from filter board B (CN 16 - 208-230 V/3~60 Hz) if the circulation pump does not exceed 10 A maximum current consumption, otherwise a dedicated power supply is required.
- In any case, the 0-10 V signal must be used to control the inverter supplying the hydronic unit. In this case, connect the external inverter to terminals CN 108 (0-10 V) on the expansion board.
- The programming of the external inverter must ensure that the pump is set to correctly cover the flow rate range required by the application.

10.17 External 3-way valve SV1 control

- The unit can run an external 3-way valve that can be used for domestic hot water production. The 3-way valve should be 208-23 power supply
- The valve must be wired according to the wiring diagram at terminals CN 125 (208-230 V/1~60 Hz) on the expansion board. More details are given in chapter 9.20 dedicated to this function

10.18 System load pressure switch

- A normally open pressure switch hydraulically connected to the circulation pump power supply must be connected to terminal CN 117 (12 VDC) on the expansion board to protect the pump from operating with large amounts of air in the circuit and to protect against cavitation phenomena.
- The device is mandatory for units with inverter pump integrated in the unit.
- Therefore, provide a well on the unit's water supply pipe for this purpose.
- The pressure switch must have an output with the following characteristics: 12 VDC.
- Where there is no pressure switch, in the case of an external hydronic pumping kit with separate protection, the contacts must be bridged as shown on the wiring diagram.

10.19 Use remote keypad control

The wired keypad on the unit can be removed and installed with a connection of up to 10 m away.

With a separate power supply, it can be connected up to 300 m away.

Power output provided with the unit.

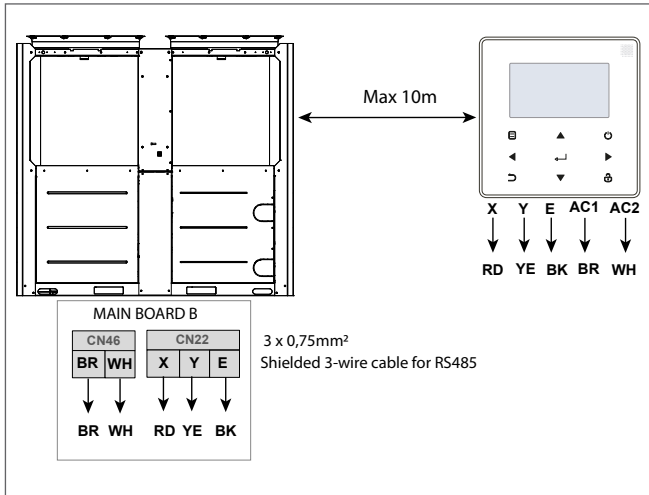

- **Note:** for installation of the HMI at more than 10 m of distance, the power supply of the HMI should be not taken from the unit but by a dedicated receptable through the transformer supplied with the unit or equivalent.

i The cable supplied for the control should be in double o reinforced insulation.

10.20 Unit in modular configuration

See specific chapter at the end of the manual.

10.22 Connection of units in cascade

With units connected in cascade, the unit address must be set on DIP switch ENC1.

With 0-F valid, 0/1 indicates the Master unit and 2-F indicates the Slave units.

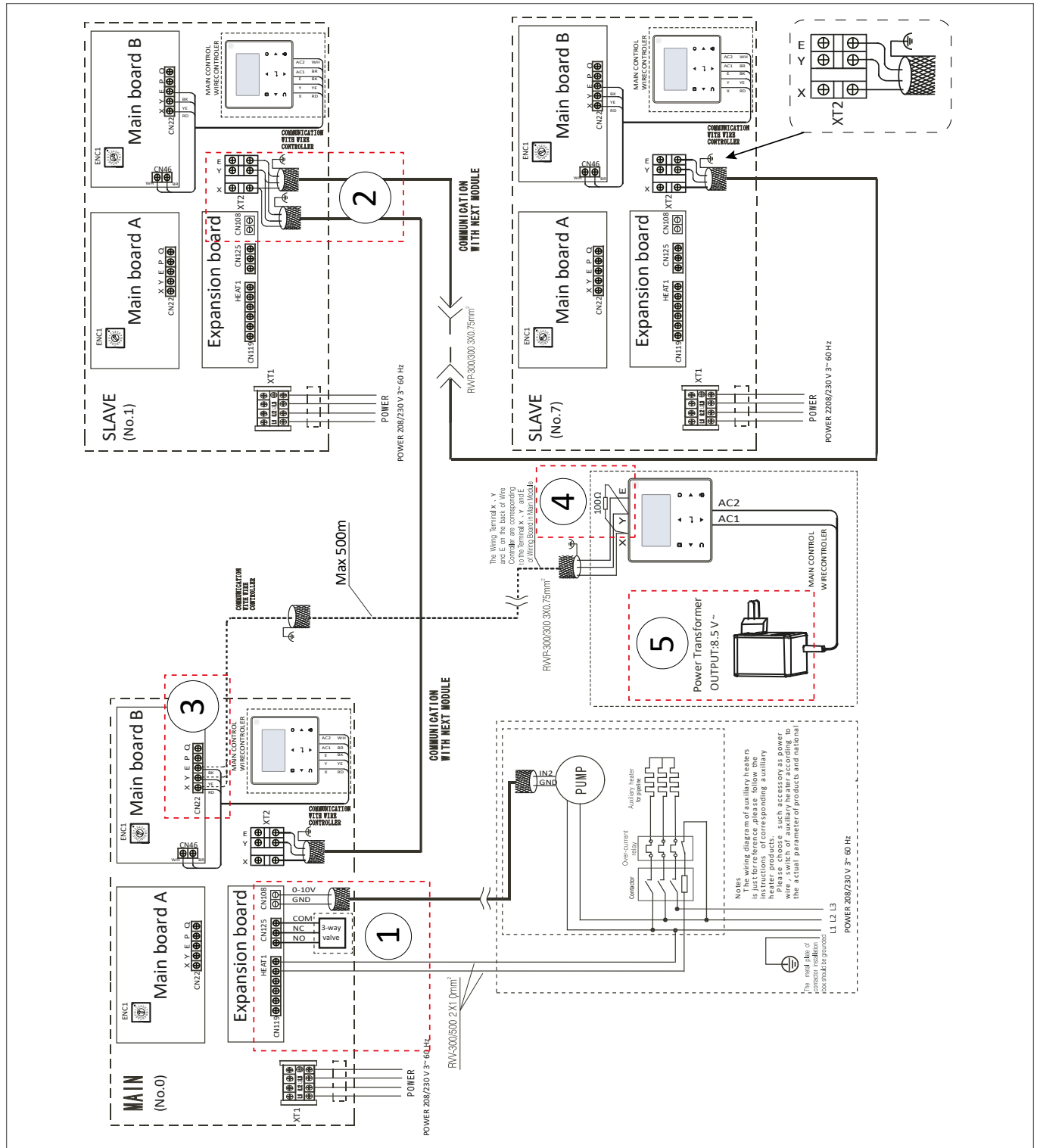

Connections to be provided by customer

- 1 All external devices must be connected to the MASTER unit
- 2 M/S connection: maximum of 7 slaves and total maximum of 8 units
- 3 Connect the HMI remote keypad (where remote is required)
- 4 Termination heater mandatory
- 5 Connect transformer for HMI remote keypad power supply

11. Start-up

The operations indicated should be performed by qualified technicians with specific training on the product.

Upon request, the service centres can perform the start-up.

The electric, hydraulic connections and the other work of the system are the responsibility of the installer.

Please agree upon the start-up date with the service centre with sufficient advance.

Following commissioning procedure is mandatory, not only at the first commissioning, but also in all the restarting of the system after long-time shutdown.

Attention

- ▶ **A slight buzz noise is normal when the pump with inverter integrated is powered on**

Before checking, please verify the following:

- the unit should be installed properly and in compliance with this manual
- the electrical power supply line should be isolated at the beginning
- the unit isolator is open, locked and equipped with the suitable warning
- make sure no voltage is present

Attention

- ▶ **After turning off the power, wait at least 5 minutes before accessing to the electrical panel or any other electrical component.**
- ▶ **Before accessing check with a multimeter that there are no residual voltages.**

11.1 Start-up sequence

For details refer to the different manual sections.

Unit OFF power supply

		✓
1	safety access	
2	suitable frame to withstand unit weight + people weight	
3	functional spaces	
4	air flow: correct return and supply (no bypass, no stratification)	
5	considered level to be reachable by snow	
6	considered main winds: there are deflectors, windbreaks, suitable anchor system	
7	lack of chimneys / corrosive atmospheres / pollutants	
8	structure integrity	
9	fans run freely	
10	unit on vibration isolators	
11	unit on level ground	
12	there is condensate drainage (only for heat pump units)	
13	unit input water filter + shut-off valves for cleaning	
14	hydraulic connections as per recommended diagram (check presence of flexible interface for vibration dampering)	
15	expansion tank (indicative volume = 10% system content)	
16	minimum system water content	
17	system washed + water quality check	
18	loaded system + corrosion inhibitor	
19	antifreeze protection: glycol solution, possible heating cable, thermal insulation of piping	
20	system under pressure + vented	
21	refrigerant circuit visual check	
22	earthing connection	
23	power supply features	
24	Customer connections: electrically connected, configured	
25	verify that power connection and ground connections are locked safely and in case tighten them before the power supply	
26	verify if the plant is acceptable with particular focus of special requirements for multiple units installation (plant layout, M/S connections, position of components to run the system)	
27	verify that fuse, switch, wire capacity is meeting the requirements	
28	verify absence of error with unit OFF (in case of error firstly remove source of error and then restore the error and start the unit)	
29	leak test	

11.2 Start-up sequence

For details refer to the different manual sections.

Unit ON power supply

			✓
1	compressor crankcase heaters operating at least since 8 hours		
2	off-load voltage measure		
3	phase sequence check		
4	manual pump start-up and check of flow-rate / head		
5	shut-off valve refrigerant circuit open		
6	unit ON		
7	load voltage measure		
8	verify the lack of bubbles in the liquid light (if applicable)		
9	check of all fan operating: no abnormal noises or vibrations		
10	measure return and supply water temperature		
11	measure super-heating and sub-cooling		
12	run tests in both heat and cool mode (only for heat pump units)		
13	check of absence of vibrations or abnormal noise and possible impact on the building's activities		
14	pump configuration: dip-switch S1-3, S1-4	*	
15	temperature configuration: dip switch S1-2 DIP switch configuration is part of the wiring diagram and service manual.		
16	remote control enabling (if applicable): dip switch S1-1 DIP switch configuration is part of the wiring diagram and service manual.		
17	HEAT1 and HEAT2 backup heater control configuration	*	
18	Climatic curve configuration	*	
19	Energy monitoring configuration	*	
20	dip-switch configuration consistent with the equipment supplied and the desired configuration (an inconsistent DIP switch configuration will cause FP errors)		
21	adjust the minimum outlet of the water pump to ensure that the minimum water flow-rate in the system, under the most unfavourable configuration conditions, is 110% of the minimum flow-rate indicated in the documentation		
22	Verify any problem in reaching the higher setpoint desired for the application		
23	Verify the correct operation of the unit and the control of external devices		
24	scheduling customisation		
25	check that all panels are closed and fastened properly		
26	complete and available unit documentation		
27	enable DHW (if applicable)		
28	enable energy saving modes (if desired by the customer)		
29	adjust the minimum set point in cooling mode, coherent with the application and to the glycol content charged in the system.		
30	check the correct date and hour		
31	enable snow-blowing switch if the site can have strong snow fall (it's suggested to enable it)		
32	enable silent mode according to the customer needs (if applicable)		
*	Refer to the Service Manual for detailed instructions		

11.3 Refrigeration circuit

- 1 Check carefully the refrigerating circuit: the presence of oil stains can mean leakage caused by transportation, movements or other).
- 2 Check that the refrigerant circuit is under pressure: use unit pressure gauges, if fitted, or service pressure gauges or check the unit's operating status.
- 3 Make sure that all the service outlets are closed with proper caps; if caps are not present a leak of refrigerant can be possible.
- 4 Open the valves of the refrigerant circuit, if there are any.

Attention

- ▶ **In case of low pressure it's possible that a leak is present.**

In this case refrigerant should be fully recovered and the unit filled with nitrogen to find the leak and fix it as a second step.

Attention

- ▶ **Welding cannot be done until the gas from the system is fully discharged.**

Before to inject refrigerant again in the system the whole refrigerant system must be completely dry thanks to the operation of a vacuum pump.

The vacuum level should last at least 3 hours and reach a pressure level below 50 Pa. Connect vacuum pipe on low-pressure port.

Connect vacuum pipe on low-pressure port.

Refrigerant needs to be injected in low pressure side and the quantity of refrigerant to be injected is reported in the label of the unit.

For small losses small amount of refrigerant can be charged in the system during the operation waiting some time to check the operation of the unit.

But in this case consider that the total amount of refrigerant is not well known.

This can lead to undercharged or overcharged systems that can have performance reduction and operation range reduced.

Fully drain/recharge the system to ensure that it charges properly.

During the injection if the pressure of the system and the refrigerant service cylinder equalizes, force the pump on to be able to pump in more refrigerant in the system.

Never inject substances different from refrigerant R32 or nitrogen in the system for any reason during service activities.

Attention

- ▶ **Do not accelerate the defrost process or clean source heat exchanger manually.**
- ▶ **Never touch any laking refrigerant since it can cause severe frostbite.**
- ▶ **Do not touch refrigerant pipes during or just after the circuit operation since pipes can be very hot or very cold resulting in a burn or frostbite.**

- ▶ **Use always glover if you have to touch the piping and do it carefully since also with glover there can be a residual risk.**

11.4 Electric Circuit

- 1 Verify that the unit is grounded.
- 2 Check the conductors are tightened as the vibrations caused by handling and transport might cause these to come loose.
- 3 Connect the unit by closing the sectioning device, but leave it on OFF.
- 4 Check the grid voltage and frequency values which must be within the limits: 208-230/3/60
- 5 Check and adjust the phase balance as necessary: it must be lower than 2%

Attention

- ▶ **Working outside of these limits can cause irreversible damages and voids the warranty.**

11.5 Options

Menu accessible only after having entered the password.

Access reserved only to specifically trained personnel.

Changing the parameters can cause irreversible damage if done not correctly.

11.6 Start-up report

Identifying the operating objective conditions is useful to control the unit over time.

With unit at steady state, i.e. in stable and close-to-work conditions, identify the following data:

- total voltages and absorptions with unit at full load
- absorptions of the different electric loads (compressors, fans, pumps etc)
- temperatures and flows of the different fluids (water, air) both in input and in output from the unit
- temperature and pressures on the characteristic points of the refrigerating circuit (compressor discharge, liquid, intake)

The measurements must be kept and made available during maintenance interventions.

12. Control

This paragraph is applicable only to the wired controller. Read this document carefully and follow its instructions before operating the wired controller.

Always observe all the operative instructions and conserve the document to the end user operation after commissioning and maintenance phase.

If you, as user are not sure on how to operate the unit, contact your installer.

12.1 Panel

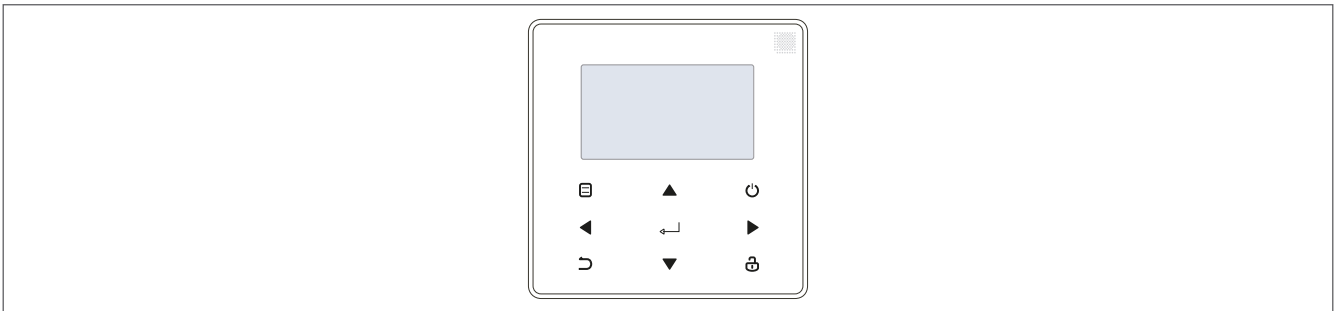

12.2 Controller specifications

Voltage range AC: 8 - 12 V

Operating temperature: -20 – 60 °C

Operating humidity: 40 - 90%

12.3 Buttons

Button	Name	Function
	UNLOCK	Locks/unlocks the buttons
	UP DOWN	Changes the current setpoint
	MENU	Opens the various menus from the HOME screen
	UP DOWN LEFT RIGHT	Moves the cursor, changes the selection, changes the set value.
	ENTER	Confirm an operation or change the menu page.
	ON OFF	Switches on/off.
	BACK	Returns to the previous level/page.

12.4 Lock/Unlock keys

Press for 3 seconds.	
----------------------	--

12.5 Switch-On/Off

Press	
-------	--

12.6 Unit in modular configuration

The information displayed on ALL controllers refers to the MASTER unit.

On the slave controllers, only the password-protected SERVICE menu can be opened.

12.7 Display

Icon	Meaning
 Cool	Cooling
 Heat	Heating
 DHW	Domestic hot water
OFF	Controller off
	Weekly timer active
	Compressor in operation
	Fan in operation
	Pump in operation
	Backup electric heater in operation
	Manual antifreeze or defrosting in operation
	Remote control: the unit is set from the keypad to be controlled by a remote terminal or by a remote selector switch.
	SILENT MODE
	Button lock
	Timer active
	Alarm: indicator on when there is a fault or a protection is tripped.

12.8 Select language

At the first unit start-up.

English	Français	Español
Português	Italiano	Deutsch
Română	български	Ελληνικά
Polski	Chinese	

After selecting the language, select “YES” and confirm to access the control address setting.

SETTING ADDRESS	
CONTROLLER ADDRESS	◀ 0 ▶
CONTROL ENABLE	◀ Yes ▶
MODBUS ENABLE	◀ NO ▶
MODBUS ADDRESS	◀ 1 ▶

The DHW mode is divided into single pump (no need to select the address) and multiple pumps (need to select address 00-15, and the address of the unit without DHW function is skipped directly).

Only TwS/T5s and address can be set in cooling, heating and DHW production.

Tw and T5 can only be displayed, not be set.

DHW can only be power on/off under the mode setting if the function is enabled via the access in Service Menu.

Access Service Menu -> Enable DHW function -> Enable DHW function also from the User Menu -> Define the priority of DHW from User Menu -> Activate DHW function from Mode Menu.

The steps are as follow:

SERVICE MENU
WRONG PASSWORD. ENTER AGAIN 000

SERVICE MENU
STATE QUERY
CLEAR HISTORY ERRORS
SETTING ADDRESS
HEAT CONTROL

SERVICE MENU
TEMPERATURE COMPENSATION
PUMP CONTROL
MANUAL DEFROST
LOW OUTLETWATER CONTROL

SERVICE MENU
VACUUM SWITCH
ENERGY SAVING SWITCH
DHW ENABLE
FACTORY DATA RESET

Activate DHW function.

DHW ENABLE	
DHW ENABLE	◀ NO ▶

Please consider that basing on the operation limits of the unit, the unit can limit the temperature of the water produced to protect itself. In such cases additional source is needed to reach the setpoint on water side.

Cooling setpoint limit can be reduced below 5 °C / 41 °F if needed enabling the Low temperature operation from the Service Menu and configuring the glycol content in the project menu.

In such cases:

- Glycol should be added to the system.
- The freezing point temperature of the antifreeze solution should be less than the coldest temperature of the site minus 5.5 °C / 10 °F.
- Use 30% glycol in volume or other anti-freeze percentage in line with the application setpoint and site coldest temperature.

12.9 Restoring control mode settings

This procedure restores the default settings.

Example: incorrect language selection.

Switch the control off and back on.

Press + +

Complete the operation within 60 seconds.

1	2	3
4	5	6
7	8	9

Press the buttons from left to right, from top to bottom, click -> -> -> ...

Select numbers 1 to 9, wait for 100% initialization and enter the FCT page.

The version number is displayed. All set parameters are reset to the default parameters and saved. All mode settings are deleted.

Switch the power supply back on and exit the FCT.

12.10 Set Date, Time, Language

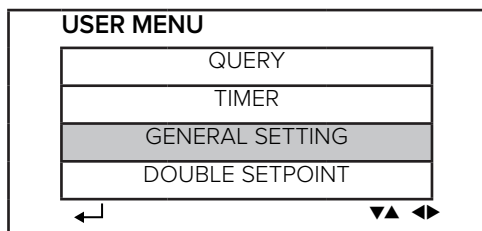
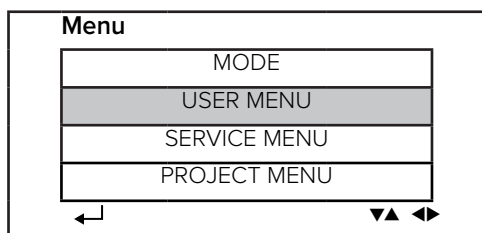

GENERAL SETTING	
YEAR	◀ 2022 ▶
MONTH	◀ 7 ▶
Day	◀ 6 ▶
12-24HOUR	◀ 12 ▶
Time	◀ 10 ▶
1/2	

GENERAL SETTING	
MINUTE	◀ 55 ▶
AM/PM	◀ AM ▶
LANGUAGE	◀ ▶
BACKLIGHT OFF DELAY(s)	◀ 60 ▶
2/2	

GENERAL SETTING	
Unit setting	◀ S1 ▶
Buzzer	◀ NO ▶
3/2	

12.11 Set MODE and TEMPERATURE

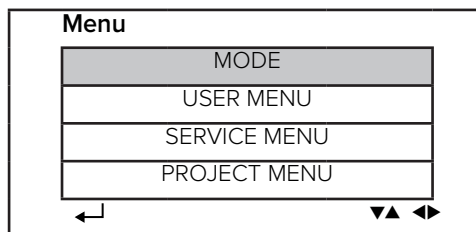

Press	
Select Mode	▲ ▼
Confirm	
Select the mode or the temperature	◀ ▶
Control the mode or the temperature	▲ ▼
Confirm	

If no operations are performed for more than 60 seconds, the system automatically saves the mode setting and returns to the home page.

- ▶ Please note that the mode menu is invalid when the unit is controlled by modbus.

12.12 Double setpoint

The unit is capable of handling two different setpoints, in both heating and cooling modes.

The value can be set with the user interface.

Activation is via a dry contact on the specific terminal block.

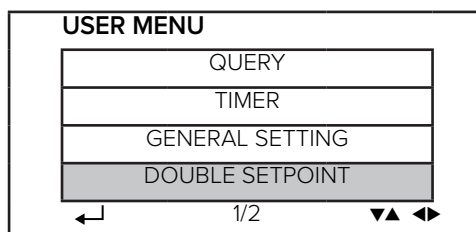
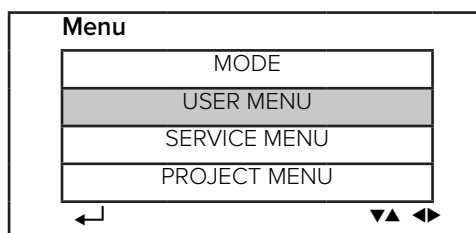

DOUBLE SETPOINT	
DOUBLE SETPOINT	◀ DISABLE ▶
SETPOINT COOL_1	◀ 7 ▶ °C
SETPOINT COOL_2	◀ 10 ▶ °C
SETPOINT HEAT_1	◀ 35 ▶ °C
SETPOINT HEAT_2	◀ 30 ▶ °C
1/2	

12.13 Snow protection function

If enabled, the function activates the fans in order to prevent a build-up of snow.

The fans start for 2 minutes every 30 minutes when the air temperature is below 3°C and the unit is stopped.

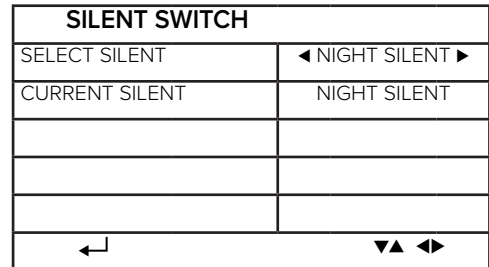
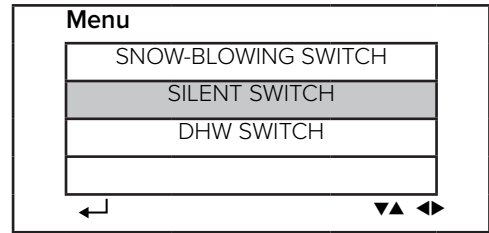
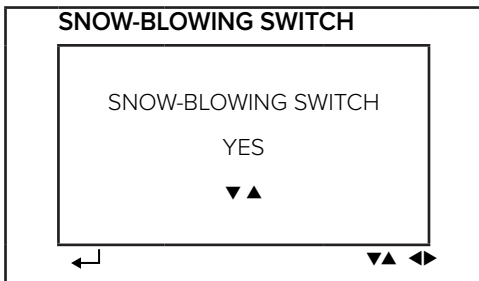
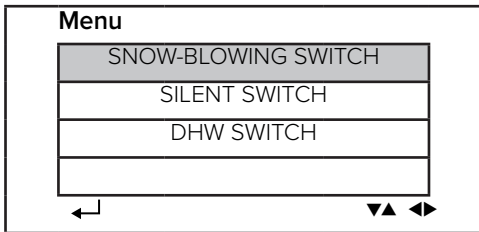
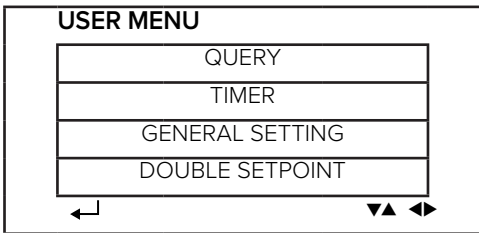
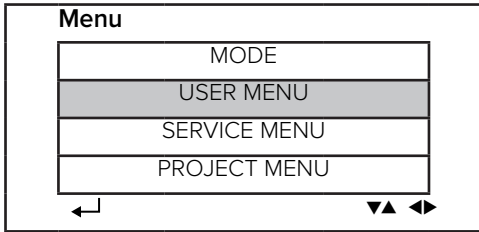

12.15 Domestic hot water

The unit is capable of handling domestic hot water production.

A dedicated valve diverts the water flow from the system to the domestic hot water tank until the DHW setpoint set on the user interface is attained.

The function must be enabled from the user interface, first from the SERVICE MENU and then from the USER MENU

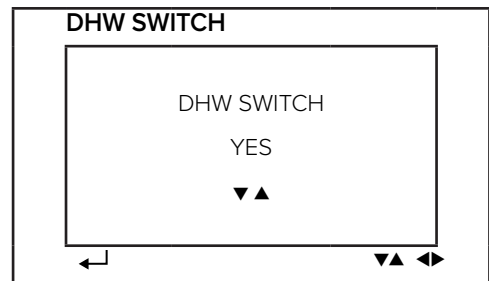
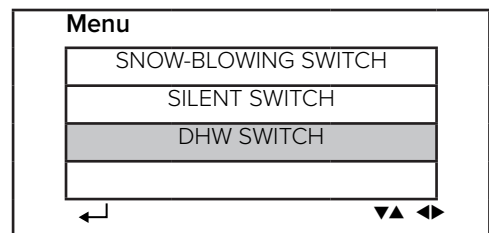
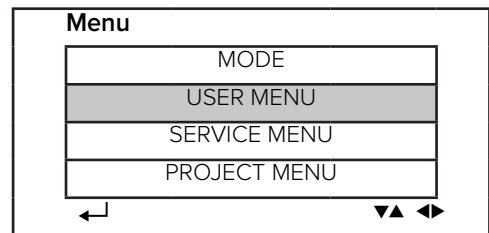

12.14 Silent mode

The SILENT MODE function lowers the sound emission level, which is especially useful at night.

The compressor and fan speed is reduced.

There are four silence levels available: Standard, Silent, Super silent, Night.

Refer to the technical data in the different modes for the noise level reduction and power reduction levels of each sound configuration.

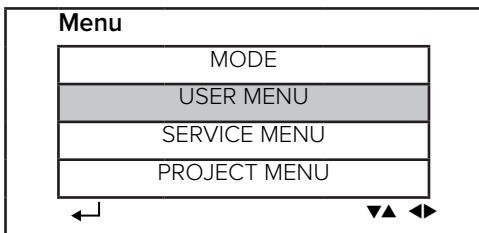

STATE QUERY	
DEFROSTING STATE	
00 01 02 03 04 05 06 07	
08 09 10 11 12 13 14 15	
E2 SOFTWARE	
END	
←	9/9 ▼▲▶

QUERY	
STATE QUERY	
TEMP QUERY	
HISTORY ERRORS QUERY	
←	▼▲▶

TEMP QUERY	
SELECT ADDRESS	◀ 11 ▶
INLET WATER TEMP	25 °C
OUTLET WATER TEMP	25 °C
TOTAL OUTWATER TEMP	25 °C
AMBIENT TEMP	25 °C
←	1/2 ▼▲▶

QUERY	
STATE QUERY	
TEMP QUERY	
HISTORY ERRORS QUERY	
←	▼▲▶

HISTORY ERRORS QUERY	
SELECT ADDRESS	◀ 11 ▶
1 2 3 4 5 6 7 8	
EU: 11/03/2020 15:05	
Tz sensor error	
←	▼▲▶

QUERY	
8:04 02-02-2022 Wed	
E2 Main control and wired control transmission error	
←	▼▲▶

12.17 Timer

A daily or weekly schedule can be set.

If the unit is controlled via remote ON-OFF or via Modbus, the timers are disabled.

Menu	
MODE	
USER MENU	
SERVICE MENU	
PROJECT MENU	
←	▼▲▶

USER MENU	
QUERY	
TIMER	
GENERAL SETTING	
DOUBLE SETPOINT	
←	▼▲▶

TIMER	
DAILY TIMER	
WEEKLY SCHEDULE	
←	▼▲▶

TIMER	
DAILY TIMER(DISALBE)	
WEEKLY SCHEDULE(DISALBE)	
←	▼▲▶

Daily programming

DAILY TIMER	
TIMER	◀ 1 ▶
ACT	◀ OFF ▶
TIME ON	◀ 10:00 ▶
TIME OFF	◀ 12:00 ▶
MODE	◀ HEAT ▶
←	1/2 ▼▲▶

DAILY TIMER	
TWS	◀ 40 ▶ °C
SILENT MODE	◀ NIGHT SILENT1 ▶
←	2/2 ▼▲▶

Only one setting is enabled between DAILY TIMER and WEEKLY SCHEDULE. If any pattern in WEEKLY SCHEDULE is set to ON DAILY TIMER is disabled.

DAILY TIMER can be set across days, but WEEKLY TIMER can not. Users can set up to two timers, and set the On and OFF time with 10 minutes interval.

The user can program also operation mode (heating, cooling, DHW for unit configured with single pump; only cooling and heating modes can be selected for multiple pumps).

Furthermore the user can also set each segment of the timer.

If the timer is set invalid the HMI displays as follows:

DAILY TIMER	
Timer1 is useless.	
The start time is same to the end time	
←	▼▲▶

Weekly schedule

The day set for Timer 1 or Timer 2 for that day is displayed at the top.

WEEKLY SCHEDULE	
WEEKLY SCHEDULE	◀ MON ▶
WEEKLY SWITCH	◀ ON ▶
←	▼▲▶

MONDAY TIMER	
TIMER	◀ 1 ▶
ACT	◀ OFF ▶
TIME ON	◀ 10:00 ▶
TIME OFF	◀ 12:00 ▶
MODE	◀ HEAT ▶
←	1/2 ▼▲▶

MONDAY TIMER	
TWS	◀ 40 ▶ °C
SILENT MODE	◀ NIGHT SILENT1 ▶
←	2/2 ▼▲▶

12.18 Unit statuses

Code	Description
	Standby: Main unit address (left 88) + Online units (right 88), Power on: Display frequency Defrost: dFdF (alternately displayed with current operating frequency)
0.xx	Host address
1.xx	Outdoor unit matching (e.g. R32 model: display 70; R290 model: display 70/60/50)
2.xx	Online units (effective host)
3.xx	T4 capacity correction (reserved display "1")
4.xx	Operating mode (8 shutdown, 1 cooling, 2 heating, 4 hot water)
5.xx	Fan speed (0-35)
6.xx	Fan speed (reserved display "0")
7.xx	T3 (min)
8.xx	T4
9.xx	Outlet water temperature of T5 water tank
10.xx	Taf1
11.xx	Taf2
12.xx	Tw total outlet water temperature of the unit
13.xx	Twi unit inlet water temperature
14.xx	Two unit outlet water temperature
15.xx	Tz total cooling outlet temperature (for heating water side plate exchange refrigerant outlet temperature)
16.xx	THeatR heat recovery sensor temperature (reserved display "--")
17.xx	Exhaust temperature 1
18.xx	Exhaust temperature 2 (reserved display "--")
19.xx	Radiator temperature 1
20.xx	Radiator temperature 2 (reserved display "--")
21.xx	Exhaust superheat Tdsh
22.xx	Compressor current A
23.xx	Compressor B current (reserved display "--")
24.xx	--
25.xx	THeatR heat recovery sensor temperature (reserved display "--")
26.xx	Exhaust temperature 1
27.xx	Exhaust temperature 2 (reserved display "--")
28.xx	Radiator temperature 1
L.xx	Radiator temperature 2 (reserved display "--")
30.xx	Exhaust superheat Tdsh
31.xx	Compressor current A

Code	Description
32.xx	Compressor B current (reserved display "--")
33.xx	Static pressure selection (default 0 static pressure)
34.xx	DC voltage A (actual value * 10)
35.xx	DC voltage B (reserved display "--")
36.xx	Frequency limit number (reserved) (0: no frequency limit; 1: T4 frequency limit; 2: Tp exhaust frequency limit; 3: Tz total cooling frequency limit (refrigeration high pressure frequency limit); 4: Tf module temperature frequency limit; 5: Two outlet water frequency limit 6: pressure frequency limit; 7: current frequency limit; 8: voltage frequency limit)
37.xx	Defrosting process status (first digit: T4 selection scheme; second digit: interval in the scheme; the third and fourth digits together indicate the defrosting timing)
38.xx	E fault: 1 for fault, 0 for no fault (reserved for 90kw)
39.xx	Defrosting scheme
40.xx	Initial frequency
41.xx	Tc (saturated temperature corresponding to high pressure) point inspection value +30
42.xx	Te (saturated temperature corresponding to low pressure) point inspection value +30
43.xx	T6a
44.xx	T6b
45.xx	Main control software version number
46.xx	Expansion board software version number
47.xx	Last first fault
48.xx	Last second fault
49.xx	Last third fault
50.xx	Last fourth fault
51.xx	Last fifth fault
52.xx	Last sixth fault
53.xx	----

12.19 Alarms

Alarm reset: switch the unit off and on again.

NOTE

- ▶ **Before resetting an alarm, identify and remove the cause of the alarm.**
- ▶ **Repeated resets can cause irreversible damage.**

The unit is in protection mode in the following conditions:

- High pressure or protection due to discharge temperature
- low voltage
- compressor current protection

- frequency protection of the inverter compressor
- high coil temperature
- high temperature difference between the inlet water and the outlet water
- antifreeze protection
- discharge temperature sensor malfunction
- low evaporator temperature
- frequency protection by voltage
- compressor inverter malfunction
- fan motor protection
- water return high temperature, in cooling mode
- low pressure antifreeze protection
- high temperature of the inverter compressor module

When the unit fails or is in protection mode, the water pump continues working (except for water flow alarm, voltage protection, phase sequence protection).

All of the temperature sensors are classed as faulty when the voltage on the corresponding input is lower than 0,05 V or higher than 4,95 V.

After an error has been signalled a circuit a unit or a system of unit will stop. The error is eliminated after the sensor has been restored.

In case the units runs under abnormal operation, failure protection code will display on both control panel and wired controller and the alarm indicator on wired controller will flash with 1 Hz frequency.

The display codes are shown in the table below:

Code	Description	Tipo
E0	Main control EPROM error	A
E1	Phase sequence error of main control board check	A
E2	Communication failure between master and the HMI or master and salve	A
2E2	Communication failure between main control and extension board	A
3E2	Communication failure between master and salve in a unit	
E3	Total water outlet temperature sensor failure	A
E4	Unit water outlet temperature sensor failure	B
1E5	Condenser tube temperature sensor T3A failure	C
E6	Water tank temperature sensor T5 failure	A/B
E7	Ambient temperature sensor failure	B
E8	Power supply phase sequence protector output error	A
E9	Water flow detection failure	A/B

Code	Description	Tipo
1Eb	Taf1 the pipe of the tank antifreeze protection sensor failure	A/B
2EB	Taf2 cooling evaporator low-temperature antifreeze protection sensor failure	B
Ed	System discharge temperature sensor failure	C
1EE	EVI plate heat exchanger refrigerant temperature T6A sensor failure	C
2EE	EVI plate heat exchanger refrigerant temperature T6B sensor failure	C
EF	Unit water return temperature sensor failure	B
EP	Discharge sensor failure alarm	C
EU	Tz sensor failure	C
P0	System high-pressure protection or discharge temperature protection	C
1P0	System high-pressure switch disconnect protection	C
P1	System low pressure protection Severe refrigerant leakage protection	C
P3	T4 ambient temperature too high in cooling mode	B
P4	1P4 System A current protection	C
	2P4 System A DC bus current protection	
P6	Inverter module failure	C
P7	High temperature protection of system condenser	C
P9	Water inlet and outlet temperature difference protection	B
PA	Abnormal water inlet and outlet temperature difference protection	B
PC	Cooling evaporator pressure too low	C
PE	Cooling evaporator low temperature antifreeze protection	B
PH	Heating T4 too high temperature protection	B
PL	Tfin module temperature too high protection	C
1PU	DC fan A module protection	C
1bh	Module 1 failure	C
H5	Voltage too high or too low	A
1H9	Compressor inverter module is not matched	C
HC	High pressure sensor failure	C
1HE	No inset A valve error	C
2HE	No inset B valve error	C

Code	Description	Tipo
3HE	No inset C valve error	C
1F0	IPM module A transmission error	C
F2	Superheat insufficient	C
F4	1F4 module 1L0 or 1LE protection occurs for 3 times in 60 minutes	C
1F6	A system bus voltage error (PTC)	C
Fb	Low pressure sensor error	C
Fd	Suction temperature sensor error	C
1FF	DC fan A error	C
FP	DIP switch inconsistency of multiple water pumps	A
1L10	Overcurrent protection	C
1L11	Transient phase current overcurrent protection	C
1L12	Phase current overcurrent lasts 30s protection	C
1L20	Module over temperature protection	C
1L31	Low bus voltage error	C
1L32	High bus voltage error	C
1L33	Excessively high bus voltage error	C
1L34	Phase loss error	C
1L43	Phase current sampling bias abnormal	C
1L45	Motor code not match	C
1L46	IPM protection	C
1L47	Module type not match	C
1L50	Startup failure	C
1L51	Out of step error	C
1L52	Zero speed error	C
L60	Fan motor phase loss protection	C
L65	IPM short circuit error	C
L66	FCT detection error	C
L6A	Open circuit of U-phase upper tube	C
L6B	Open circuit of U-phase lower tube	C
L6C	Open circuit of V-phase upper tube	C
L6D	Open circuit of V-phase lower tube	C
L6E	Open circuit of W-phase upper tube	C
L6F	Open circuit of W-phase lower tube	C

The last column of the alarms table shows which of the following it belongs to in case of fault.

A = shuts down all units in M/S

B = shuts down the unit affected by the alarm

C = shuts down only the circuit affected by the alarm

13. Maintenance

13.1 Safety

Operate in compliance with safety regulations in force.

To carry out the operations use protection devices: gloves, goggles, helmet, headphones, protective knee pads.



All operations must be carried out by personnel trained on possible risks of a general nature, electrical and deriving from operating with equipment under pressure.

Only qualified personnel can operate on the unit, as required by the regulation in force.

13.2 General

Maintenance must be done by authorized centres or by qualified personnel.

The maintenance allows to:

- maintain the unit efficiency
- increase the life span of the equipment
- check information and data of unit operation to understand the state of the unit efficiency and avoid possible damages

Warning

- ▶ **before carrying on any activities, please verify the following**
- ▶ **the electrical power supply line should be isolated at the beginning**
- ▶ **the unit isolator is open, locked and equipped with the suitable warning**
- ▶ **make sure no voltage is present**
- ▶ **After turning off the power, wait at least 5 minutes before accessing to the electrical panel or any other electrical component.**
- ▶ **Before accessing check with a multimeter that there are no residual voltage.**
- ▶ **Do not wash the unit with water since this can cause electrical shocks or fire.**
- ▶ **In any case if the power cord is damaged it must be replaced.**
- ▶ **Never leave the unit unattended during installation or operating when external panel are removed.**

- ▶ **Do not touch pipes during and immediately after operation as pipes may be hot and could burn your hands. Use always wear protective gloves during such procedures.**

13.3 Inspections frequency

Perform an inspection every 6 months minimum.

The frequency, however, depends on the use.

In the event of frequent use it is recommended to plan inspections at shorter intervals:

- frequent use (continuous or very intermittent use, near the operating limits, etc)
- critical use (service necessary)

Warning

- ▶ **Before performing any work, carefully read: SAFETY WARNINGS FOR OPERATIONS ON UNITS CONTAINING R32**

ATTENTION

- ▶ **Do not go up to the surface**
- ▶ **Do not place heavy objects.**

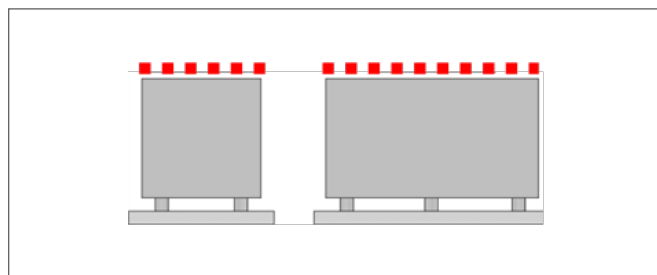

13.4 Unit booklet

It's advisable to create a unit booklet to take notes of the unit interventions.

In this way it will be easier to adequately note the various interventions and aid any troubleshooting.

Report on the booklet:

- date
- intervention description
- carried out measures etc.

13.5 Standby mode

If a long period of inactivity is foreseen:

- turn off the power
- avoid the risk of frost (empty the system or add glycol)
- Turn off the power to avoid electrical risks or damages by lightning strikes.
- With lower temperatures keep heaters turned on in of the electrical panel (option).

It's recommended that the re-start after the stopping period is performed by a qualified technician, especially

after seasonal stops or seasonal switching.

When restarting, refer to what is indicated in the “start-up” section.

Schedule technical assistance in advance to avoid misunderstandings and to guarantee that the system can be used when required.

13.6 Recommended periodical checks

intervention frequency (months)	1	6	12
1	presence of corrosion		X
2	panel fixing		X
3	fan fixing	X	
4	coil cleaning	X	
5	water filter cleaning	X	
6	water: quality, ph, weight of glycol (%)	X	
7	check the heat exchanger efficiency	X	
8	circulating pumps		X
9	check of the fixing and the insulation of the power cables		X
10	verify water loss from the hydraulic system	X	
11	check of the earthing cable		X
12	electric panel cleaning		X
13	power contactors status (if applicable)		X
14	terminals closing, cable insulation integrity		X
15	voltage and phase unbalancing (no load and on-load)		X
16	absorptions of the single electrical loads	X	
17	test of the compressor crankcase heaters	X	
18	Checking for leaks	X	
19	measurement of refrigerant circuit operating parameters (temperatures, pressures, etc.)		*
20	water pressure relief valve and system load pressure switch *	X	
21	testing of protection devices: pressure switches, thermostats, flow switches, etc. (no fuse plug)		*
22	control system test: setpoint, climatic compensations, capacity stepping, water / air flow-rate variations	X	
23	control device test: alarm signalling, thermometers, probes, pressure gauges etc..	X	
24	check of cables and auxiliary components driven by the heat pump		X
25	verify the status of the HEAT1 and HEAT2 in DHW tank. They should be clean and in good condition		X

Warning

- ***Refer to the local regulations. Companies and technicians performing installation, maintenance/repair, leak control and recovery operations must be CERTIFIED as set out by the local regulations.**

13.7 System drain

The system must be drained only if necessary.

Do not drain the system periodically; this can lead to corrosion.

- 1 empty the system
- 2 empty the exchanger, use all of the shut-off valves and grub screws present
- 3 blow the exchanger with compressed air
- 4 dry the exchanger with hot air; for greater safety, fill the exchanger with glycol solution
- 5 protect the exchanger from air by filling it with nitrogen
- 6 take the drain caps off the pumps

Any antifreeze liquid contained in the system should not be discharged freely as it is a pollutant. It must be collected and reused.

Before start-up, wash the system.

It's recommended that the re-start after the stopping period is performed by a qualified technician, especially after seasonal stops or seasonal switching.

When restarting, refer to what is indicated in the "start-up" section.

Schedule technical assistance in advance to avoid misunderstandings and to guarantee that the system can be used when required.

13.8 Compressor crankcase heater

Check:

- closing
- Operation

13.9 Water side exchanger

The exchanger must be able to provide the maximum thermal exchange, therefore its inner surfaces must be cleaned from dirt and incrustations.

After long-time operation oxides and other minerals will be settled on heat transfer surface of the heat exchanger.

These substances affect heat transfer performances if there is too much scale on it, increasing energy consumption and leading to operating range reduction or alarms.

Check the difference between the outlet water temperature and the evaporation temperature: if the difference is greater than 8°C–10°C, it is advisable to clean the exchanger.

Organic acids such as formic acid, citric acid and acetic acid may be used to clean the surface from the scale settled on heat transfer surfaces.

In no way fluoroacetic or fluoride acid should be used for such treatment due to the erosion risk and leakage risk as a consequence.

It must be cleaned:

- with circulation opposite to the usual one
- at least 1.5 times faster than the nominal one
- with a suitable moderately acid product

- keeping the cleaning product for an adequate time and at a temperature suitable for the expected dirtying conditions
- after washing, flush with water to remove/prevent detergent residues
- water-side heat exchanger cleaning should be done by professionals.
- after cleaning is completed, consider that neutralization treatment of the waste water is needed. This should be done according to national and local laws and standards by relevant company authorized for such kind of waste treatment activities.

13.10 Water filter

Check that no impurities prevent the correct passage of water.

13.11 Flow Switch

- check operation
- remove scale from the blade

13.12 Circulation pumps

Check:

- there are no leaks
- status of the bearings (anomalies are indicated by abnormal noises and vibrations)
- the terminal protection covers are closed and the cable holders are properly positioned

13.13 Thermal and acoustical insulation

Check the status of the insulations: if necessary, apply glue and renew the seals.

13.14 Pressure relief valve and fusible plug

The pressure relief valve must be replaced:

- if it is activated
- if there is oxidation
- based on the date of manufacture, in accordance with local regulations.

13.15 Structure

- Wash it at least once or twice a year, depending on exposure (pollution, salt deposits, dirt).

Clean with neutral detergent and cold or warm water (max 30°C).

Do not use solvents or acid, alkaline, abrasive products.

- Check the condition of the parts making up the structure.

Treat those parts of the unit subject to oxidation, with paints act at eliminating or reducing the oxidation phenomena.

- Check fastening of the unit external panelling.

Bad fastening give rise to anomalous noises and vibrations.

13.16 Air side exchanger

- ▶ **Accidental contact with the exchanger fins can cause cutting injuries: use protective gloves.**

The coil must give the maximum thermal exchange, therefore its surface must be cleaned from dirt and incrustations.

Clean at least every three months.

The cleaning frequency must be increased according to the build-up of dirt/dust and the environment (e.g. coastal areas with chlorides and salts or industrial areas with aggressive substances).

Clean the air inlet side.

Use a soft brush, vacuum dirt exhauster, pressurised air jet or high-pressure washer.

Keep the direction parallel to the fins to avoid damage.

Check that the aluminium fins are not bent or damaged, in the event of damages contact the authorised service centre which will “comb” the coil to restore optimal air flow

13.17 Electric fans

Check:

- ensure that the fan and its protection grilles are fixed properly
- the fan bearings (anomalies are indicated by abnormal noise and vibrations)
- the terminal protection covers are closed and the cable holders are properly positioned

13.18 Extraordinary maintenance

After an extraordinary maintenance has been carried on, service personnel needs always to verify that the work has been done properly aligned to the original design of the unit.

In particular there are some constrction in Class II in the unit (external movable panels) and, after maintenance for such parts, it should be ensured that:

- or the construction in class II are restored
- or movable panels are grounded
- or there is a negligible risk of contact between power cables and external panels

This can be done with an appropriate clamping of the wires to the pipes.

- ▶ **It's always suggested to make pictures before the extraordinary maintenance and to restore the wiring similarly.**

14. Decommissioning

14.1 Disconnection

Warning

- ▶ **Before performing any work, carefully read: SAFETY WARNINGS FOR OPERATIONS ON UNITS CONTAINING R32**

- ▶ **Comply with the national regulation.**

Avoid leak or spills into the environment.

Before disconnecting the unit, the following must be recovered, if present:

- refrigerant gas
- Anti-freeze solutions in the hydraulic circuit

Awaiting decommissioning and disposal, the unit can also be stored outdoors, as bad weather and rapid changes in temperature do not harm the environment provided that the electric, cooling and hydraulic circuits of the unit are intact and closed.

Do not dispose this product as unsorted municipal waste.

Collection of such waste separately for special treatment is necessary.

Do not dispose of electrical appliances with municipal waste, but use the dedicated disposal collection points throughout the territory.

If this is done, hazardous substances can leak into the environment getting into food chain damaging your health and well-being.

Electrical and electronic equipment must be disposed of together with all of its parts.

To dispose of “household” electrical and electronic equipment, the manufacturer recommends you contact an authorised dealer or an authorised ecological area.

“Professional” electrical and electronic equipment must be disposed of by authorised personnel through established waste disposal authorities around the country.

This equipment may contain:

- refrigerant gas, the entire contents of which must be recovered in suitable containers by specialised personnel with the necessary qualifications;
- lubrication oil contained in compressors and in the cooling circuit to be collected;
- mixtures with antifreeze in the water circuit, the contents of which are to be collected;
- mechanical and electrical parts to be separated and disposed of as authorised.

When machine components to be replaced for maintenance purposes are removed or when the entire unit reaches the end of its life and needs to be removed from the installation, waste should be separated by its nature and disposed of by authorised personnel at existing collection centres.

15. Residual risks

15.1 General

In this section the most common situations are indicated, as these cannot be controlled by the manufacturer and could be a source of risk situations for people or things.

Danger zone

This is an area in which only an authorised operator may work.

The danger zone is the area inside the unit which is accessible only with the deliberate removal of protections or parts thereof.

15.2 Handling

The handling operations, if implemented without all of the protection necessary and without due caution, may cause the drop or the tipping of the unit with the consequent damage, even serious, to persons, things or the unit itself.

Handle the unit following the instructions provided in the present manual regarding the packaging and in compliance with the local regulations in force.

Should the refrigerant leak please refer to the refrigerant "Safety sheet".

15.3 Installation

The incorrect installation of the unit could cause water leaks, condensate accumulation, leaking of the refrigerant, electric shock, poor operation or damage to the unit itself.

Check that the installation has been implemented by qualified technical personnel only and that the instructions contained in the present manual and the local regulations in force have been adhered to.

The installation of the unit in a place where even infrequent leaks of flammable gas and the accumulation of this gas in the area surrounding the area occur could cause explosions or fires.

Carefully check the positioning of the unit.

The installation of the unit in a place unsuited to support its weight and/or guarantee adequate anchorage may result in consequent damage to things, people or the unit itself.

Carefully check the positioning and the anchoring of the unit.

Easy access to the unit by children, unauthorised persons or animals may be the source of accidents, some serious.

Install the unit in areas which are only accessible to authorised person and/or provide protection against intrusion into the danger zone.

15.4 General risks

Smell of burning, smoke or other signals of serious anomalies may indicate a situation which could cause damage to people, things or the unit itself.

Electrically isolate the unit (yellow-red isolator).

Contact the authorised service centre to identify and resolve the problem at the source of the anomaly.

Accidental contact with exchange batteries, compressors, air delivery tubes or other components may cause injuries and/or burns.

Always wear suitable clothing including protective gloves to work inside the danger zone.

Maintenance and repair operations carried out by non-qualified personnel may cause damage to persons, things or the unit itself.

Always contact the qualified assistance centre.

Failing to close the unit panels or failure to check the correct tightening of all of the panelling fixing screws may cause damage to persons, things or the unit itself.

Periodically check that all of the panels are correctly closed and fixed.

If there is a fire the temperature of the refrigerant could reach values that increase the pressure to beyond the safety valve with the consequent possible projection of the refrigerant itself or explosion of the circuit parts that remain isolated by the closure of the tap.

Do not remain in the vicinity of the safety valve and never leave the refrigerating system taps closed.

15.5 Electric parts

An incomplete attachment line to the electric network or with incorrectly sized cables and/or unsuitable protective devices can cause electric shocks, intoxication, damage to the unit or fires.

Carry out all of the work on the electric system referring to the electric layout and the present manual ensuring the use of a system thereto dedicated.

An incorrect fixing of the electric components cover may lead to the entry of dust, water etc inside and may consequently electric shocks, damage to the unit or fires.

Always fix the unit cover properly.

When the metallic mass of the unit is under voltage and is not correctly connected to the earthing system it may be as source of electric shock and electrocution.

Always pay particular attention to the implementation of the earthing system connections.

Contact with parts under voltage accessible inside the unit after the removal of the guards can cause electric shocks, burns and electrocution.

Open and padlock the general isolator prior to removing the guards and signal work in progress with the appropriate sign.

Contact with parts that could be under voltage due to the start up of the unit may cause electric shocks, burns and electrocution.

When voltage is necessary for the circuit open the

isolator on the attachment line of the unit itself, padlock it and display the appropriate warning sign.

15.6 Moving parts

Contact with the transmissions or with the fan aspiration can cause injuries.

Prior to entering the inside of the unit open the isolater situated on the con-nection line of the unit itself, padlock and display the appropriate warning sign.

Contact with the fans can cause injury.

Prior to removing the protective grill or the fans, open the isolator on the attachment line of the unit itself, padlock it and display the appropriate warning sign.

15.7 Refrigerant

The intervention of the safety valve and the consequent expulsion of the gas refrigerant may cause injuries and intoxication.

Always wear suitable clothing including protective gloves and eyeglasses for operations inside the danger zone.

Should the refrigerant leak please refer to the refrigerant "Safety sheet".

Contact between open flames or heat sources with the refrigerant or the heating of the gas circuit under pressure (e.g. during welding operations) may cause explosions or fires.

Do not place any heat source inside the danger zone.

The maintenance or repair interventions which include welding must be carried out with the system off.

15.8 Hydraulic parts

Defects in tubing, the attachments or the removal parts may cause a leak or water projection with the consequent damages to people, things or shortcircuit the unit.

Please consider that in case of multiple unit installation common supply and return pipe should be oversized based on the numbers of units in the system.

Bad operation of the system due to under-sizing of these pipes is in charge of the plant designer/installer.

16. Unit in modular configuration

Maximum number of connectable units: **8**

The system is completely controlled by the Master unit.

Each module can be equipped with an inertial system storage tank.

16.1 Control logic

In a cascade system, Tw (supply water flow temperature for the entire system) and TWS (set point temperature) are measured by the master unit.

The master unit will periodically (standard time 80 seconds) evaluate the current load based on the outlet water temperature, the set point distance and speed difference of the water temperature.

Depending on evaluation of the load performed by the master unit, the number of units running will either be kept stable, increased or reduced.

Once it is switched on, a unit will continue to operate according to its own logic (T4, water temperature, etc.).

16.2 Tw control probe

The probe TW must be installed on the common supply line of the units, as far away as possible.

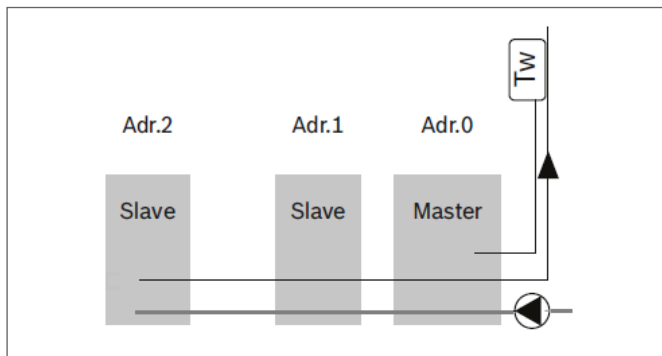

16.3 Domestic hot water

In a cascade system with DHW provision, the system configuration must be as follows:

- each unit must be fitted with its own pump, the S1-3 dial on all the units must be ON. Each unit must be fitted with its own external DHW boiler because the DHW load will be evaluated by each slave unit. In a system containing units with and without DHW valve, the highest address numbers must be assigned to the DHW units.

The three-way valve SV1 that controls the switching between heating mode and domestic hot water production mode is on CN125 of the expansion slave board. It is mandatory for the grid device to have a coil with a power voltage of 208-230 V, not supplied. It must be purchased from a third-party supplier.

16.4 Electrical connections

All units must be electrically connected to each other via

the X-Y-E BUS.

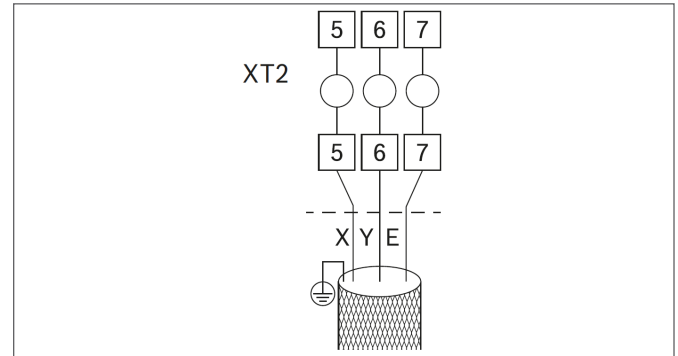

i For electrical connections between several units, refer to the Connection of units in cascade chapter.

All system devices controlled by the unit, including probes Taf1, Tw and T5, must be wired to the MASTER unit.

16.5 System with reversed return connection

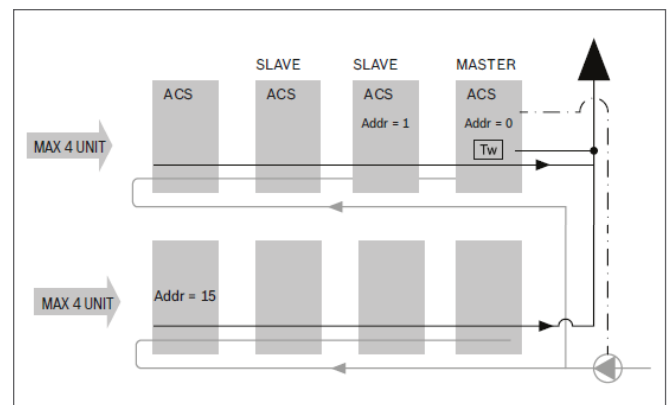

16.6 Input and output manifolds

Cooling capacity (kW)		In-out water piping
Min	Max	
15	30	DN40
30	90	DN50
90	130	DN65
130	210	DN80
210	325	DN100
325	510	DN125
510	740	DN150
740	1300	DN200

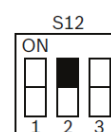
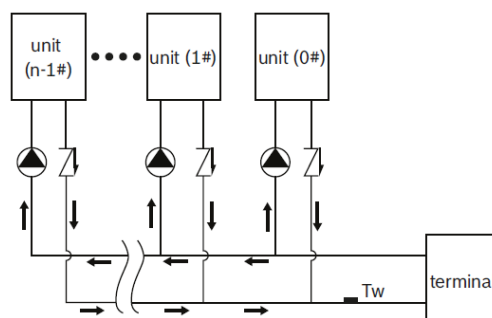

16.7 Single/multiple pump system

Configure DIP switch S1-3 according to the type of system.

16.7.1 Single water pump

A check valve is not required in single pump configuration.

Pump control is only enabled on the master unit

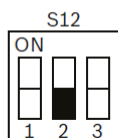
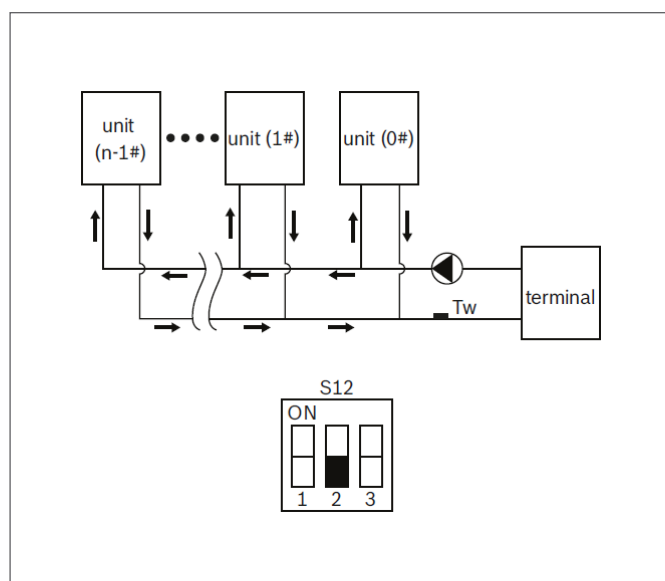

16.7.2 Multiple water pumps

A check valve is required for each unit in multiple pump configuration.

Pump control is enabled on each unit

16.8 Addressing

Each connected module is identified by an address, from 0 to 7: the Master unit is identified as 0.

Set the correct date and time on each unit before connecting them to the network

Enable multiple configuration on each unit:

dip S1-3:

- ON units with on-board pump
- OFF units without on-board pump and a single pump in the system

The modular configuration consists of two networks: the controller network and the unit network (main boards).

Each network can have up to 7 addresses (from 0 to 7) and must be addressed separately.

Each network has its own master, which must have address = 0.

If some of the slave units do not have the DHW option:

- configure a unit without a DHW option as the master.
- assign the higher addresses to the slave units with DHW option
- For Single Pump systems, all units must be configured consistently with the Master. Only the Master manages the single external 3-way valve. In the design, consider that the units will switch simultaneously to fulfil the required load. It will not be possible to have simultaneous production on both the system side and the DHW side.

16.8.1 Addressing units

Units are addressed using encoder ENC4 on the back of the board.

The address is the number on the encoder.

The address is shown on display DSP1.

E.g.:

MASTER : address = 0 encoder = 0

SLAVE 1 : address = 1 encoder = 1

SLAVE 7 : address = 7 encoder = F

The address of the unit is shown on display “DSP1” on the main board.

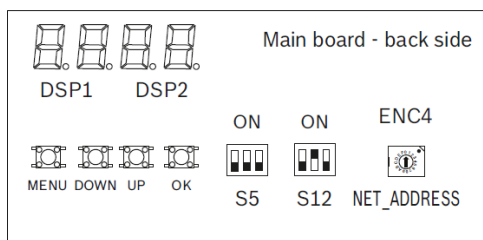

16.8.2 Addressing controls

A maximum of 8 controls can be addressed, with addresses from 0 to 7; e.g.

- 8 units with relative controller on board, one of which is the master
- 6 units with relative controller on board + a remote controller as the master

Press ▼▲ to select SETTING ADDRESS.

Press ◀▶ to set the address

Press OK to confirm

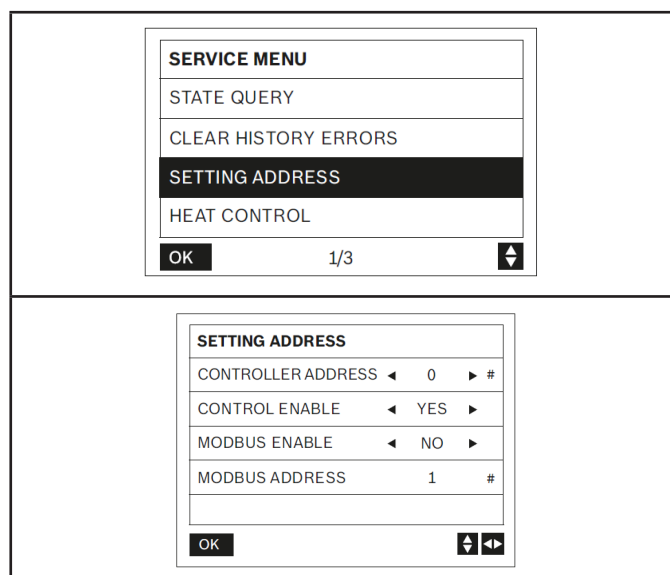

16.9 Remote ON-OFF

With the units in modular configuration, remote control must be applied to the master unit, which transmits it to the slave units.

16.10 Start-up

Complete system management is carried out by the master unit, identified by address 0.

Thermoregulation takes place on the supply temperature of the entire system (T_w).

At switch-on, when a load is requested, the units are switched on in sequence based on their address, in numerical order.

When the load decreases, the units are switched off following the same sequence.

Example in cooling mode:

If $T_w \geq \text{set point} + 10^\circ\text{C}$

- the control activates 50% of the resources in sequence based on the set address.
- after a time interval (default: 240 seconds)
- if the load increases, additional resources are activated
- if the load decreases, the units are switched off following the same sequence (first start, first stop).

If $T_w < \text{set point} + 10^\circ\text{C}$ (in cooling mode)

- the control activates only the master unit.
- after a time interval (default: 240 seconds)
- if the load increases, additional resources are activated based on the set address
- if the load decreases, the master unit switches off.

16.11 Alarms

In the event of an alarm on one of the system units, there could be different outcomes:

- in the event of an alarm on a slave unit, the other system units will continue to operate
- in the event of a communication or common sensor alarm on the master unit, the entire system will stop.

Refer to the Service Manual for more details.

17. Modbus

17.1 Communication specifications: RS - 485

Protocol	ModbusRTU: 9600, 8, N,1
Transmission speed	9600pbs
Data bit	8 data bits
Parity bit	None parity
Stop bit	1 stop bit

Connections

For single unit, connect Modbus to R-, R+ of the HMI.

For modular unit, connect Modbus to R-, R+ of the master unit's HMI and connect the units together via the XT2 terminals.

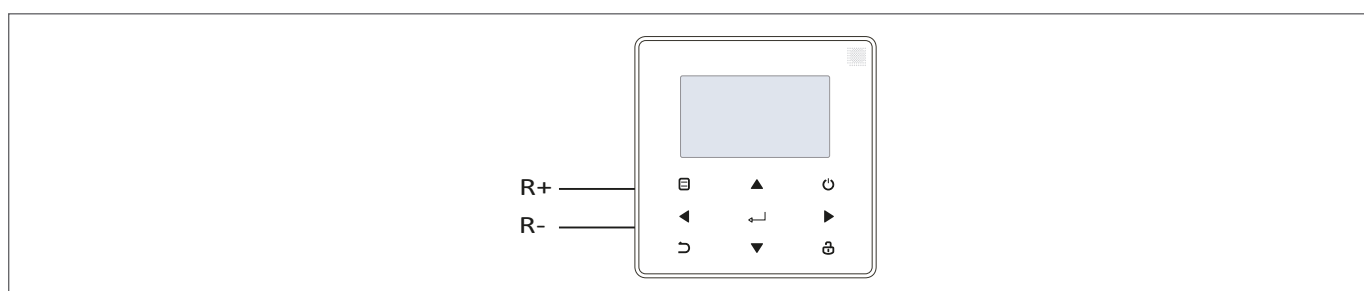

Enabling

SERVICE MENU → SETTING ADDRESS → Modbus enable → YES

Data in English only

Reg	Name	Description
0	Modeset	(1Cool,2Heat, 4 DHW,8Off) DHW mode is only valid for hot water models and single pump systems Invalid when external unit remote control = ON For cooling only/FC models, only 1 Cooling, 8 Off can be set.
1	Set Two Temperature A	COOL MODE Only Cool & Free Cooling : (Max (-8, TSafe °C ~ 20 °C) Heat pump: R32-10 °C ~ 25 °C R290 -5 ~ 25 °C HEAT MODE Only Cool & Free Cooling: (25 °C ~ 55 °C) Heat pump: R32 Normal 25 ~ 60 °C High temperature 25 ~ 65 °C Heat Pump: R290 conventional 25 ~ 75 °C High temperature 25 ~ 85 °C
2	Set Two Temperature B	COOL MODE Only Cool & Free Cooling : (Max (-8, TSafe °C ~ 20 °C) Heat pump: R3 2-10 °C ~ 25 °C R290 -5 ~ 25 °C HEAT MODE Only Cool & Free Cooling: (25 °C ~ 55 °C) Heat pump: R32 Normal 25 ~ 60 °C High temperature 25 ~ 65 °C Heat Pump:R290 conventional25 ~ 75 °C High temperature 25 ~ 85 °C
3	Offset Temperature OFFSET-C/OFFSET-H	COOL(0~15 °C) HEAT (0~30 °C)
4	Water Set Temperature	T5sMin °C ~ T5sMax °C (sent by master control) Heat pump: R32 Normal 30 ~ 60 °C High temperature 30 ~ 70 °C Heat Pump: R29 0Regular 20 ~ 70 °C High temperature 20 ~ 80 °C (Available for single pump) Invalid for models without hot water machine
5	WaterOffset Temperature	Reserved Set 0
6	Clear Lock Errs	(0 is invalid, 1 clears the fault, other values are invalid) Clear all lock errors

Reg	Name	Description
7	Snow blowing switch	Enable/Disable 1/0
8	Reserved	Reserved
9	Metric and Imperial unit switching	0: Metric 1: Imperial
100	Silent Mode	1: Standard mode 2: Silent mode 3: Night silent mode 1 4: Night silent mode 2 5: Night silent mode 3 Night silent mode 3 6: Night silent mode 4 7: Super silent mode
101	DOUBLE SETPOINT Dual target temperature setting	Enable/Disable1/0
102	SETPOINT COOL_1 First target temperature in cooling	COOL MODE Only Cool & Free Cooling : (Max(-8, T _{Safe} °C ~20 °C) Heat pump: R32-10 °C ~ 25 °C R290 -5 ~ 25 °C
103	SETPOINT COOL_2 Second target temperature in cooling	COOL MODE Only Cool & Free Cooling : (Max(-8, T _{Safe} °C ~ 20 °C) Heat pump: R32-10 °C ~ 25 °C R290 -5 ~ 25 °C
104	SETPOINT HEAT_1 First target temperature in heating	HEAT MODE Only Cool & Free Cooling: (25 °C ~ 55 °C) Heat pump: R32Normal 25 ~ 60 °C High temperature 25 ~ 65 °C Heat Pump:R290conventional25 ~ 75 °C High temperature 25~85 °C
105	SETPOINT HEAT_1 First target temperature in heating	HEAT MODE Only Cool & Free Cooling: (25 °C ~ 55 °C) Heat pump: R32 Normal 25 ~ 60 °C High temperature 25 ~ 65 °C Heat Pump: R290 conventional25 ~ 75 °C High temperature 25 ~ 85 °C
106	COOL MODE ENABLE Temperature compensation function setting in cooling	Enable/Disable
107	T4_COOL_1 Temperature compensation point 1 in cooling mode	15 ~ 30 °C
108	T4_COOL_2 Temperature compensation point 2 in cooling mode	35 ~ 45 °C
109	OFFSET-C Temperature compensation value in cooling	0 ~ 15 °C
110	HEATMODE ENABLE Temperature compensation function setting in heating	Enable/Disable
111	T4_HEAT_1 Temperature compensation point 1 in heating mode	-25 ~ 15
112	T4_HEAT_2 Temperature compensation point 2 in heating mode	15 ~ 30 °C
113	OFFSET-H Temperature compensation value in heating	0 ~ 30 °C
114	FORCED HEAT2 OPEN Forced auxiliary electric heater 2 of single pump	Enable/Disable1/0 (Available for single pump) Before the electric auxiliary heating 2 is enabled, it is not allowed to set forced opening Invalid for models without hot water machine
115	DHW SWITCH Water heating switch	Enable/Disable1/0 (Available for single pump)

Reg	Name	Description
116	TWO_COOL_DIFF Differential temperature of unit outlet water in cooling	1 °C ~ 5 °C
117	TWO_HEAT_DIFF Differential temperature of unit outlet water in heating	1 °C ~ 5 °C
118	DT5_ON Differential temperature of unit outlet water in water heating	2 °C ~ 10 °C Invalid for models without hot water machine
119	DT1S5 Temperature difference of heat exchange in water heating	5 °C ~ 20 °C Invalid for models without hot water machine
120	TIM_CAP_ADJ Capacity adjustment period	60S~360S Adjustment range 20s
121	TW_COOL_DIFF/ TW_HEAT_DIFF Differential temperature of total outlet water	COOL MODE: 1 °C ~ 5 °C HEAT MODE: 1 °C ~ 5 °C
122	RATIO_COOL_FIRST Initial startup ratio in cooling	5~100% Adjustment range 5%
123	RATIO_HEAT_FIRST Initial startup ratio in heating	5~100% Adjustment range 5%
124	T_DIFF_PRO Protection of temperature difference between inlet and outlet water	Normal 8 °C ~ 15 °C High temperature 8 °C~25 °C
125	T_FROST Defrost period	20min ~120min Adjustment range 5min
126	T_DEFROST_IN Entry temperature of defrosting	-5 °C ~ 5 °C
127	T_FROST_OUT Exit temperature of defrosting	-10 °C ~ 10 °C
128	HEAT1 ENABLE Auxiliary electric heater	Enable/Disable 1/0
129	TEMP_AUXHEAT1_ON Available ambient temperature of auxiliary electric heater	0 °C ~ 10 °C Invalid for cooling only/FC models -15 °C ~ 10 °C The available ambient temperature for pipeline auxiliary electric heating needs to be ≥HEAT1Heat pump stops working ambient temperature
130	TW_HEAT1_ON Opening water temperature of auxiliary electric heater	Heat Pump: 0 °C ~ 59 °C The "open water temperature" must be lower than the "close water temperature" (This parameter is invalid)
131	TW_HEAT1_OFF Closing water temperature of auxiliary electric heater	Heat Pump: 1 °C ~ 60 °C The "Shut-off water temperature" must be higher than the "Open water temperature" (This parameter is invalid)
132	HEAT2 ENABLE Auxiliary electric heater of water tank is enabled/disabled	Enable/Disable 1/0 (single pump effective) Invalid for models without hot water machine
133	T_HEAT2_DELAY Delay opening time of auxiliary electric heater of water tank	60min ~ 240min Adjustment range: 5min (valid for single pump) Invalid for models without hot water machine
134	DT5_HEAT2_OFF Hysteresis when auxiliary electric heater of water tank stops	2 °C ~ 10 °C (Single pump effective) Invalid for models without hot water machine

Reg	Name	Description
135	T4_HEAT2_ON Available ambient temperature of auxiliary heater electric of water tank	-5 °C ~ 20 °C (Single pump effective) Invalid for models without hot water machine -15 °C ~ 20 °C Water tank electric auxiliary heating available ambient temperature > HE-A-T2. Heat pump stops working ambient temperature
136	SWITCH ON THE PUMP Startup of inverter water pump	Enable/Disable 1/0 (single pump effective)
137	RATIO-PUMP Startup percentage of inverter water pump	30-100% Adjustment range 5% (single pump effective) Before the variable frequency water pump is turned on, the opening percentage cannot be set
138	MODBUS ENABLE Modbus write enable switch	Enable/Disable Write operation valid/write operation invalid 1/0
139	Glycol type	0 :ETHYLENEEthylene glycol 1 :PROPYLENEPropylene glycol (Available for Only Cool & Free Cooling)
140	Percent of glycol	0 ~ 50% Adjustment range 5% (Available for Only Cool & Free Cooling)
141	Protection pressure compensation value ΔPaf	0 ~ 20 : 0.0 ~ 0.2Mpa Mpa is the actual value*100, the adjustment range is 5: 0.05Mpa Psi is the actual value, which can be 0, 5, 15, 20, 30Psi (Available for Only Cool & Free Cooling) Invalid heat pump model
142	Water Coil Control	0 :AUTOMATIC 1 :MANUAL1 2 :MANUAL2 (FC models are available for Free Cooling)
143	Enter mixback Tws Rising value DtTws	1 °C ~ 3 °C (FC models are available for Free Cooling)
144	Enter mix Hysteresis Dtmix	1 °C ~ 3 °C (FC models are available for Free Cooling)
145	Enter FC margin FCoffset	1 °C ~ 3 °C (FC models are available for Free Cooling)
146	Enter FC Hysteresis FChy	1 °C ~ 3 °C (FC models are available for Free Cooling)
147	Abnormal values of inlet and outlet water temperature TWI-O ABNORMAL	1 °C ~ 5 °C
148	Minimum cooling water output LOW OUTLET WATER CONTROL	R32-10 ~ 25 °C R290 -5 ~ 25 °C
149	Power saving mode Energy saving switch	40%~100% Adjustment range 10% 100% means power saving mode is off
150	E9 delay protection time Set E9 time	2 ~ 20s
151	E9 Detection Method	1: Do not check rake flow before starting the pump 2: Check the rake flow before starting the pump
152	Minimum opening ratio of variable frequency water pump Invert pump min ratio	40 ~ Min(100%, Invert pump max ratio) Adjustment range 5% Multi-pump hot water machine
153	Maximum opening ratio of variable frequency water pump Invert pump max ratio	Max(70%, Invert pump min ratio) ~ 100% Adjustment range 5% Multi-pump hot water machine
154	Pump On Time	5 ~ 60min Adjustment range 5min

Reg	Name	Description
155	Pump Off Time	0 ~ 60min Adjustment range 5min
156	TW_COOL_DIFF Cool mode differential temperature of total outlet water	1°C ~ 5°C Conventional heat pump models, only valid for the host when the setting mode is cooling
157	TW_HEAT_DIFF Heat mode differential temperature of total outlet water	1°C ~ 5°C Invalid for cooling only and FC models Conventional heat pump models, only valid for the host when the setting mode is heating
158	Electric heating 1 start differential temperature DTW_HEAT1_ON	1°C ~10 °C
159	Electric heating delay start T_HEAT1_DELAY	15MIN~120MIN Adjustment range 5min
160	Heat pump stops working ambient temperature (HEAT1) T4_HEATPUMP_OFF1	-30~10 °C HEAT1The ambient temperature when the heat pump stops working needs to be ≤ the available ambient temperature for pipeline auxiliary electric heating
161	Pipeline electric heating forced on FORCED-HEAT1-OPEN	Enable/Disable On/Off 1/0
162	Heat pump stops working ambient temperature (HEAT2) T4_HEATPUMP_OFF2	-30~10 °C HE-A-T2 The ambient temperature of the heat pump stopping operation needs to be less than the available ambient temperature of the water tank electric auxiliary heating
163-199	Reserved	
265+(Unit Address)*100	HEAT2 STATE	0 Off, 1 On This item is not configured for non-hot water models, and the data is invalid In a single pump system, only the data of host No. 0 is valid
266+(Unit Address)*100	Tp1 Discharge temperature 1	Unit: 1 °C 255: Invalid data
267+(Unit Address)*100	ThSuction temperature	Unit: 1 °C 255: Invalid data
268+(Unit Address)*100	T3 TEMP	Minimum value of T3A and T3B, unit: 1 °C 255: Invalid data
269+(Unit Address)*100	Tz TEMP	Unit: 1 °C 255: Invalid data
270+(Unit Address)*100	T5 TEMP	Unit: 1 °C This item is not configured for non-hot water models, and the data is invalid In a single pump system, only host No. 0 has this data 255: Invalid data
271+(Unit Address)*100	Heat Pump : P PRESSURE Only Cool & Free Cooling : EVA PRESSURE	Unit: 10 kPa 0: Invalid data
272+(Unit Address)*100	MainBoard Err or protect	See the external machine fault code table
273+(Unit Address)*100	MainBoardLast Err or protect	See the external machine fault code table
274+(Unit Address)*100	HMI Software Version	Current HMI version number
275+(Unit Address)*100	Tp2 Discharge temperature2	Unit: 1 °C 255: Invalid data
276+(Unit Address)*100	T5sMin	Unit: 1 °C This item is not configured for non-hot water models, and the data is invalid 255: Invalid data
277+(Unit Address)*100	T6A TEMP	Unit: 1 °C 255: Invalid data
278+(Unit Address)*100	Wire Control Err	See the line control fault code table

Reg	Name	Description
279+(Unit Address)*100	SV6 STATE	0 Off, 1 On
280+(Unit Address)*100	Current of Compressor 2	Unit: 1A
281+(Unit Address)*100	Unit Capacity	Unit: 1kw
282+(Unit Address)*100	Defrosting Defrost	0 No, 1 Yes
283+(Unit Address)*100	Antifreeze heating belt Anti-freezing electric heater	0 Off, 1 On
284+(Unit Address)*100	Remote Control Remote Control	0 Off, 1 On The address of external unit No. 0 is read effectively
285+(Unit Address)*100	FCT working status FCT working state	0 Off, 1 On The address of external unit No. 0 is read effectively Only valid when the host enters FCT2/FCT3
286+(Unit Address)*100	Pump group status	1: Multiple pumps 0: Single pump
287+(Unit Address)*100	External machine model ODU Type	0: Normal Heat Pump Conventional heat pump 1: Only Cool 2: Free Cooling
288+(Unit Address)*100	T5sMax	Unit: 1 °C This item is not configured for non-hot water models, and the data is invalid
289+(Unit Address)*100	Safety temperature Tsafe	Unit: 1 °C (only cooling/FC model valid)
290+(Unit Address)*100	Protective pressure PAF	Unit: 10 kPa (Effective for cooling only/FC model) Invalid heat pump model
291+(Unit Address)*100	TafIIN-LET BPHE TEMP	Unit: 1 °C 255: Invalid data
292+(Unit Address)*100	MainBoardSoftware Version	Current main control board program version number Note: Old heat pump models do not have this value; when the value is 0, it means that the outdoor unit does not have this data
293+(Unit Address)*100	MainBoardEEPROM Version	Current main control board EEPROM program version number Note: Old heat pump models do not have this value; when the value is 0, it means that the outdoor unit does not have this data
294+(Unit Address)*100	COND PRESSURE	Unit: 10 kPa (valid for FC models) 0: Invalid data Note: Old heat pump models do not have this value;
295+(Unit Address)*100	T6B TEMP	Unit: 1 °C 255: Invalid data
296+(Unit Address)*100	TAF2 TEMP	Unit: 1 °C 255: Invalid data
297+(Unit Address)*100	TFIN1 TEMP	Unit: 1 °C 255: Invalid data
298+(Unit Address)*100	TFIN2 TEMP	Unit: 1 °C 255: Invalid data
299+(Unit Address)*100	TFIN3 TEMP (Reserved)	Unit: 1 °C 255: Invalid data
(2200~2299)+(Unit Address)*200	Reserved	
2300+(Unit Address)*200	DSH TEMP	Unit: 1 °C 255: Invalid data
2301+(Unit Address)*200	SSH TEMP	Unit: 1 °C 255: Invalid data
2302+(Unit Address)*200	CSH TEMP	Unit: 1 °C 255: Invalid data
2303+(Unit Address)*200	Frequency conversion pump operation percentage Invert Pump Running Percent	0 ~ 100%

Reg	Name	Description
2304+(Unit Address)*200	oldRrNewErr	Current fault(2305+(Unit Address)*200)New and old fault code parsing tags. 0: Analyze according to the old fault, the fault content refers to272+(Unit Address)*100 1: Press NewFault analysis
2305+(Unit Address)*200	MainBoard Err or protect80E0	Two analysis methods: old fault analysis and new fault analysis
2306+(Unit Address)*200	oldRrNewErrLast	Historical failures (2307+(Unit Address)*200)New and old fault code parsing tags. 0:according toOld fault analysis, fault content reference273+(Unit Address)*100 1: Press NewFault analysis
2307+(Unit Address)*200	MainBoardLast Err or protect80E0	Two analysis methods: old fault analysis and new fault analysis
(2308~2399)+(Unit Address)*200	Reserved	

FOR OVER 35 YEARS, WE HAVE BEEN
OFFERING SOLUTIONS TO ENSURE
SUSTAINABLE

Info & Contacts: www.clivet.com

